

COATS®

PANZITTA SALES & SERVICE
72 George Avenue
Wilkes-Barre, PA 18705
570-822-6720 800-822-6720
www.panzittasales.com

RC-100

Rim Clamp® Tire Changer

For servicing motorcycle and ATV tire/wheel assemblies, also single piece automotive and most light truck tire/wheel assemblies



Parts Identification

READ these instructions before placing unit in service KEEP these and other materials delivered with the unit in a binder near the machine for ease of reference by supervisors and operators.

HENNESSY INDUSTRIES, INC.

1601 J. P. Hennessy Drive, LaVergne, TN USA 37086-3565 615/641-7533 800/688-6359

HENNESSY INDUSTRIES INC. Manufacturer of AMMCO®, COATS® and BADA® Automotive Service Equipment and Tools.

Manual Part No.: 8183183 11

Revision: 10/00

Parts Identification

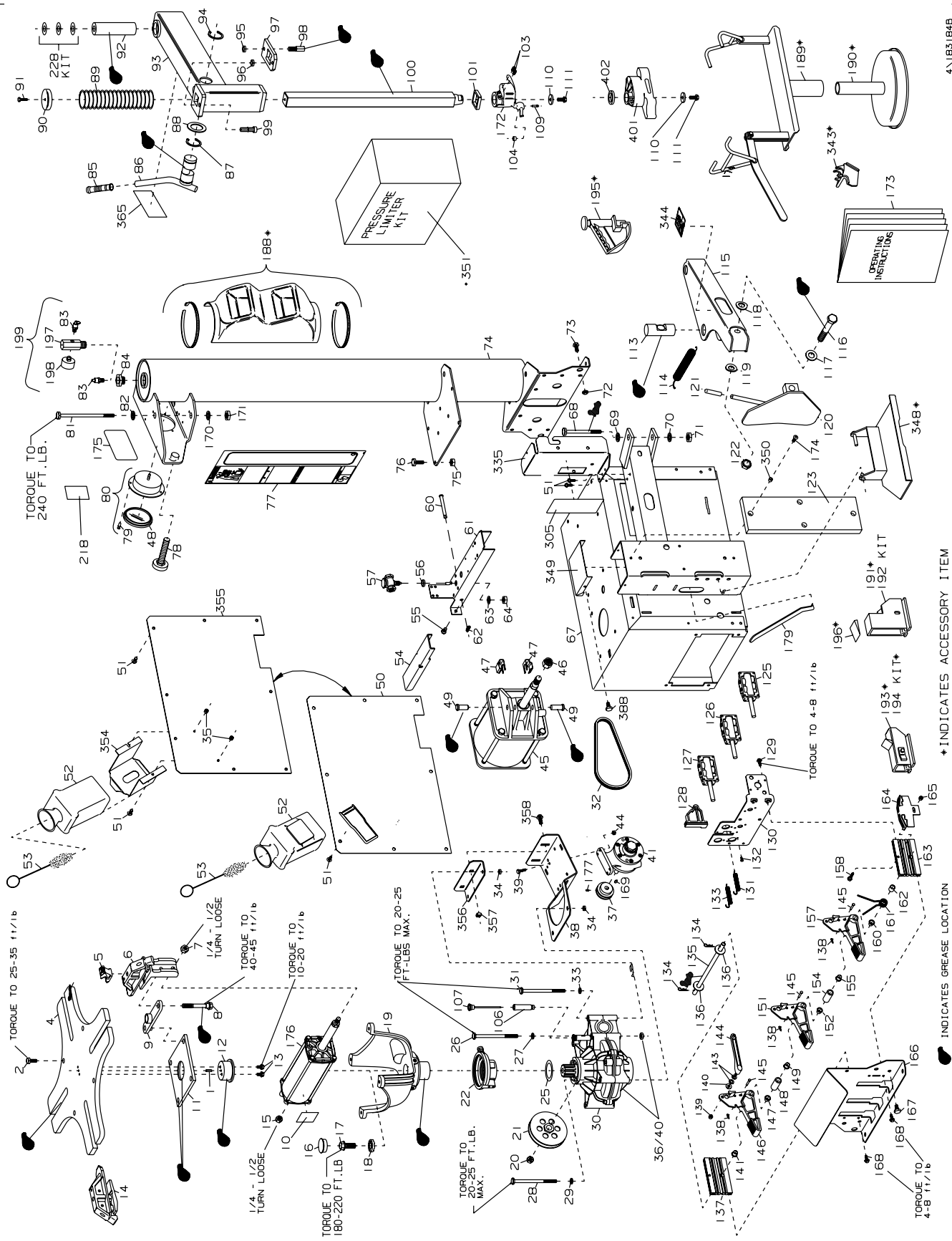

4163164B

* INDICATES ACCESSORY ITEM

● INDICATES GREASE LOCATION

Ref	Part No.	Description	Ref	Part No.	Description	Ref	Part No.	Description
1	8183476	1/4 x 3/4" Roll Pin	54	8181933	Inflation Valve Pedal (RED)	111	8106302	3/8 Whiz Lock Screw-GR.5
2	8181929	3/8-16 x 1" Gr.8 Skt. Hd. Cap Scr.	55	8102459	3/8 x 3/4 HWH Selt-Tap. Scr. Gr.5	113	8182550	B.L. Cylinder Rod Pivot Pin
4	8182952	Table Top Plate without Jets	56	8104673	1/4" Valve Bushing Small	114	8180230	Bead Loosener Spring
5	8181677	Rim Clamp	57	8104600	1/4" Valve	115	8182581	Bead Loosener Arm
6	8182662	Clamp Carrier - Cyl. End	60	8180103	Ø3/8" x 3-1/4" Clevis Pin	116	8182579	3/4-10 x 5" Gr.5 Hex Hd. Cap Scr.
7	8101039	1/2" Gr.5 Locknut	61	8181932	Inflation Bracket (RED)	117	8182457	Ø3/4 Washer
8	8181904	Table Top Link Bolt	62	8107407	Hitch Pin Retainer	118	8182558	Ø3/4" Belleville Washer
9	8181734	Pivot Plate W/C	63	8104613	Ø5/8" External Lock Washer	119	8182557	B.L. Washer Spacer
10	8183260	Decal - Nut Tightness, TT Cylinder	64	8104611	5/8 Jam Nut	120	8182473	B.L. Shoe
11	8181731	Table Top Pivot Plate	67	8183177	Chassis	121	8107107	Handle Grip
12	8181733	Pivot Block	68	8182579	3/4-10 x 5" Gr.5 Hex Hd. Cap Scr.	122	8182016	3/4-10 Nylon Insert Lock Nut
13	8183452	Flange Whiz-Lock Screw 5/16" x 5/8"	69	8182457	Ø3/4 Washer	123	8183034	B.L. PAD 5" x 16"
14	8182661	Clamp Carrier	70	8182457	Ø3/4 Washer	125	8181986	4-Way Valve W/Pull Pin
15	8101039	1/2" Gr.5 Lock Nut	71	8182016	3/4-10 Nyl. Insert Lock Nut, Gr.5	126	8181986	4-Way Valve W/Pull Pin
16	8182627	Ø1-5/8" Cap Plug	72	8106303	3/8" Whiz Lock Nut-GR.5	127	8181986	4-Way Valve W/Pull Pin
17	8181742	16MM x 40mm Gr. 10.9 Hex Hd. Bolt	73	8106302	3/8" Whiz Lock Screw-GR.5	128	8181695	Cam Mounting Block
18	8182979	16MM Washer	74	8182500	Tower/Air Receiver (RED)	129	8106301	1/4 HH Self Tap Screw-GR.5
19	8181990	Spider Assembly	75	8106303	3/8" Whiz Lock Nut-GR.5	130	8183031	Valve Mounting Bracket
20	8182162	12MM Gr. 8.8 Hex Nut	76	8106302	3/8" Whiz Lock Screw-GR.5	131	8181708	Pedal Extension Spring
21	8181658	Pulley - Transmission	77	8182962	Warning Decal (STANDARD)	132	8181989	#10-24 x 3/8" Gr.8 Skt.Hd. Cap Scr.
22	8183368	Rotary Coupling Assembly	78	8182593	Adjustment Knob Assembly	133	8181708	Pedal Extension Spring
23	8181713	Large O-Ring Seal (2-244) *	79	8107983	Fastener Plastic	134	8011609	Cotter, Hair Pin
24	8181712	Small O-Ring Seal (2-142) *	80	8107985	Flanged Air Gauge w/Fasteners	135	8183398	Pedal Shaft
25	8183156	WASHER - Ø2" x Ø2 3/4 x .010 *	81	8181172	3/4 x 7-1/2" Gr.5 Hex Hd. Cap Scr.	136	8301121	Washer
26	8110653	3/8-16 x 6" Gr.5 Capscrew *	82	8182457	Ø3/4 Washer	137	8181918	Valve Bracket Spacer Bar
27	8301032	Ø3/8" Flat Washer (Zinc Plated) *	83	8182599	200 P.S.I. Safety Valve	138	8120469	Hair Pin Cotter
28	8110653	3/8-16 x 6" Gr.5 Capscrew *	84	8101312	Reducer Bushing 3/4 X 1/4 NPT	139	8181369	1/4-20 Nylon Insert Lock Nut
29	8301032	Ø3/8" Flat Washer (Zinc Plated) *	85	8100979	Ø3/4 Handle Grip (BLACK)	140	8107635	Ø5/16 Flat Washer
30	8182965	Transmission Kit *	86	8181082	Lock Handle Lift Cam	141	8181948	Ø1/2" Nylon Bearing
31	8110653	3/8-16 x 6" Gr.5 Hex Hd. Cap Screw *	87	8181095	Ø1-5/8" Snap Ring	143	8181981	Ø5/16 Wave Washer
32	8181205	Belt	88	8182371	Ø1-5/8" Wave Washer	144	8181696	Cam Follower Lever
33	8301032	Ø3/8" Flat Washer (Zinc Plated)	89	8182028	Vertical Slide Spring	145	8183399	Ø3/16 x 1-1/2" Clevis Pin
34	8106303	3/8" Whiz Lock Nut-GR.5 *	90	8181771	Vertical Slide Cap	146	8181675	Standard Pedal
35	8181369	Nut-Nylok 1/4 - 20, Gr.5	91	8183151	5/16-18 x 3/4" Gr.8 BHSCS	147	8181948	Ø1/2" Nylon Bearing
36	8000516	3/8-16 Hex Lock Nut Gr.5	92	8181038	Swing Arm Pivot Pin	148	8181911	Pedal Spacer
37	8182571	Motor Pulley - Air Motor	93	8182577	Swing Arm (RED)	149	8181948	Ø1/2" Nylon Bearing
38	8182784	Motor Mounting Bracket (RED)	94	8181095	Ø1-5/8" Snap Ring	150	8000372	1/4" NPT x 90° ST. Elbow
39	8181984	1/4-20 x 1" Gr.5 Hex Head Screw	95	8181113	1/2-13 Jam Nut-GR.5	151	8181675	Standard Pedal
40	8000516	3/8-16 Hex Lock Nut Gr.5	96	8181113	1/2-13 Jam Nut-GR.5	152	8181948	Ø1/2" Nylon Bearing
41	8182572	Air Motor	97	8181788	Lock Plate (MACHINED)	153	8182366	1/4" NPT Close Brass Nipple
44	8181369	1/4-20 Nylon Insert Lock Nut GR.5	98	8181035	Lock Plate Lift Pin	154	8182327	Pedal Spacer
45	8183325	7" Bead Loosener Cylinder Assembly	99	8181740	1/2-13 x 1-3/4 Gr.5 Skt.Hd. Cap Scr.	155	8181948	Ø1/2" Nylon Bearing
46	8182016	3/4-16 Lock Nut-Nylon Insert GR.5	100	8182767	Vertical Slide Shaft	156	8183424	Adjustable Regulator, 1/4" NPT
47	8181912	Clevis Clip	101	8182031	Rubber Bumper	157	8181675	Standard Pedal
48	8107517	Screw On Gauge Lenses	103	8130026	3/8 x 16 x 1/2 Soc HD Set Screw	158	8181948	Ø1/2" Nylon Bearing
49	8181949	Ø5/8 x 1-38" Clevis Pin	104	8183356	Roller	159	8181977	Clevis Pin 3/16" X 1-1/4"
50	8182554	Side Cover Panel	106	8182185	Transmission Dipstick Tube	160	8181948	Ø1/2" Nylon Bearing
51	8106301	1/4" Hx. Hd. Self-tapping Scr., Gr.5	107	8182186	Transmission Dipstick	161	8181707	Torsion Spring
52	8106259	Lube Bottle (RED)	109	8183357	Set Screw/Dowell Pin 1/4 - 20 UNC	162	8181872	Torsion Spring Sleeve
53	8000491	Lube Applicator	110	8182027	Ø1.32 OD x .406 ID x 7ga. Washer	163	8181918	Valve Bracket Spacer Bar

Parts Identification

Ref No.	Description	Ref No.	Description	Ref No.	Description
164	8182670 Spring Stop	222	8106289 Ø1/4" x 22" Hose	304	8000481 Ø1/4" x 6" Hose
165	8181369 1/4" -20 Nylon Insert Lock Nut	223	8101428 Ø1/4" Hose Clamp	305	8183778 Decal - Filter Lubricator Notice
166	8182586 Foot Pedal Guard (RED)	224	8182005 Ø3/8" x 20" Nylon Tube	306	8181204 Motor - Pulley (ELECT. MOTOR)
167	8102459 3/8-16 x 3/4 Self Tap. Scr. Gr.5	225	8000378 Ø1/4" Brass St. Fitting	308	8183502 Inflation Manifold
168	8106301 1/4 HH Self Tap Screw-GR.5	226	8000378 Ø1/4" Brass St. Fitting	309	8101898 1/4" Brass St. Fitting
169	8182723 #3 Woodruff Key	227	8181998 1/4 NPT x 3/8 Tube Male Elbow	310	8101428 Ø1/4" Hose Clamp
170	8182457 Ø3/4" Washer	228	8182339 Swing Arm Shim Kit	311	8182090 Ø1/4" x 61" Hose
171	8182016 3/4-10 Nylon Insert Lock Nut	229	8182005 Ø3/8" x 20" Nylon Tube	312	8101428 Ø1/4" Hose Clamp
172	8183355 Mount/Demount Head Assembly	230	8181147 Ø3/8 x 17.25" Lg. Hose	313	8101428 Ø1/4" Hose Clamp
173	8183186 Operating Instructions(STD)	231	8181988 1/4 NPT x 3/8" Tube Male Branch Tee	314	8183421 Ø1/4" x 73" Hose (RED)
174	8182088 5/16-18 X 1 Torx Screw,GR.5	232	8101898 Ø3/8" Hose Fitting	316	8103753 Air Chuck
175	8109888 Infl. Warning Decal (STANDARD)	233	8182005 Ø3/8" x 20" Nylon Tube	317	8102390 1/4" Hose Fitting, 1/4 NPT
176	8182613 Table Top Cylinder Assembly	235	8181988 1/4 NPT x 3/8" Tube Male Branch Tee	318	8183423 Inflation Hose Assembly (RED)
177	8180217 5/16-18X3/8 SOC HD Set Scr.GR.5	237	8181999 Ø3/8" Male Str. Fitting	319	8181183 Nylon Hex Nut 5/16-18
179	8181354 Bead Lifting Tool	239	8000378 Ø1/4" Brass Str. Fitting	320	8183811 Table Top Cylinder Seal Kit
181	8183199 Soc. Hd. Cap Scr. 6mm x 16mm Gr.10.9	240	8101428 Ø1/4" Hose Clamp	321	8181622 Cylinder Bottom Cap
182	8101898 3/8" Hose Fitting	241	8106289 Ø1/4" x 22" Hose	322	8182719 1/2-13 Lock Nut-GR.5
183	8000372 1/4" X 90 Street Elbow	242	8106289 Ø1/4" x 22" Hose	323	8183771 Washer 2 1/2 O.D. x .515 I.D. x .064
185	8101898 3/8" Hose Fitting	243	8182005 Ø3/8" x 20" Nylon Tube	324	8181629 Table Top Cylinder Shaft
186	8000372 1/4" X 90 Street Elbow	244	8182005 Ø3/8" x 20" Nylon Tube	325	8181627 Cylinder Sleeve
188	8181554 Accessory Tray Kit	245	8101428 Ø1/4" Hose Clamp	326	8181620 Cylinder Top Cap
189	8108028 Tire Spreader	246	8000378 Ø1/4" Brass Str. Fitting	327	8181633 Table Top Cylinder Tie Bolt, Gr.5
190	8181329 Rim Clamp Spreader Base	247	8101428 Ø1/4" Hose Clamp	328	8103649 Ø1/4" x 12" Hose
191	8183225 Motorcycle Clamp (Tail)	248	8000376 Ø1/4" x 90° Brass Fitting	331	8183328 7" Bead Loosener Cylinder Top Cap
192	8183401 Motorcycle Clamp Kit (Tail)	250	8181999 1/4 NPT x 3/8" Malt Str. Fitting	334	8182734 Muffler
193	8235740 ATV Clamp (Tail)	251	8181191 Quick Exhaust Valve	335	8183770 Filter/Lubricator Mfg. Bracket
194	8181891 ATV Clamp Kit (Tail)	252	8000580 1/4 NPT Close Nipple	338	8130026 3/8 X 1/2" Soc. HD Set Screw-GR.8
195	8435685 Drop Center Aid	253	8181207 3/8 NPT Close Nipple	343	8183367 Bootie-Mount/Demount Head-Pkg/2
196	8183248 Plastic Clamp Jaw	254	8181195 1/2-3/8 Reducing Elbow	8183373 Bootie-Mount/Demount Head-Pkg/12	
197	8109784 Gauge Protector Manifold	255	8181206 Muffler	8183374 Bootie-Mount/Demount Head-Pinch Point Caution	
198	8108968 Air Gauge	257	8181999 1/4 NPT x 3/8" Male Str. Fitting	344	8182768 Decal - Pinch Point Caution
199	8182640 California Gauge Kit	258	8182638 7" Bead Loosener Cylinder Seal Kit	347	8182827 Filter/Lubricator
200	8101312 Reducer Bushing 3/4" x 1/4" npt	259	8183327 7" Bead Loosener Cylinder Bot. Cap	348	8183262 Lift Assembly - ATV Wheels
201	8107234 Tee 1/4" npt X 3/8" Hose	260	8182016 3/4-10 Gr.5 Nylon Insert Lock Nut	349	8183274 Cover - Vertical Channel
207	8000378 1/4" Brass St. Fitting	261	8182566 Bead Loosener Cyl. Steel Washer	350	8183287 Spacer - B.L. Torx Bolts
208	8101428 Ø1/4" Hose Clamp	262	8182566 Bead Loosener Cyl. Steel Washer	351	8183291 Kit - Pressure Limiter, RC-100
209	8101428 Ø1/4" Hose Clamp	263	8182565 Bead Loosener Cylinder Shaft	353	8182912 Air Motor Repair Kit
210	8110497 90 Deg. Male Elbow-1/8 NPT	264	8182568 Bead Loosener Cylinder Sleeve Barrel	355	8182878 Lube Bottle Bracket
211	8104844 1/4 Hose x 1/8 NPT Str. Fitting	265	8110890 1/2-13 X 9" Long HHCS-GR.5	355	8182878 Panel/Side Cover
212	8101428 Ø1/4" Hose Clamp	266	8182366 Close Nipple 1/4" npt Brass	356	8182923 Motor Adjustment Bracket
213	8104684 Ø1/4" x 8" Hose	269	8182497 Ø3/8" x 36" Hose	357	8143044 3/8-16 Tinnerman Nut
214	8000378 1/4" Brass St. Fitting	270	8101428 Ø1/4" Hose Clamp	358	8106302 3/8" Whiz Lock Screw Gr.5
215	8101428 Ø1/4" Hose Clamp	276	8000643 Tee 1/4" npt. Brass	362	8180588 Motor Key
216	8181349 Rotary Coupling	277	8181999 St Male Fitting 1/4" npt x 3/8" Tube	363	8182959 Electric Motor - 115v 60Hz
218	8109769 Decal - Release Valve	283	8000378 1/4" Brass St. Fitting	8182783 Electric Motor - 220v 50Hz	
219	8183369 Ø1/4 Hose x 1/8 NPT Str. Fting w/.062 orifice	284	8101428 Ø1/4" Hose Clamp	364	8180638 Motor Capacitor (ONLY)
220	8101428 Ø1/4" Hose Clamp	285	8104649 Poppet - 1/4" Valve	365	8183354 Decal - Clamp Pressure
221	8106289 Ø1/4" x 22" Hose	286	8102468 Poppet Spring - 1/4" Valve	366	8120325 5/16-18 x 1" Gr.5 Ser. Washer Hd.Scr.
		287	8105671 1/4" Valve End Cap	367	8180560 Ground Jumper
		303	8101428 Ø1/4" Hose Clamp	368	8181511 Motor Cable Assembly

Parts Identification

PANZITTA SALES & SERVICE
72 George Avenue
Wilkes-Barre, PA 18705
570-822-6720 800-822-6720
www.panzittasales.com

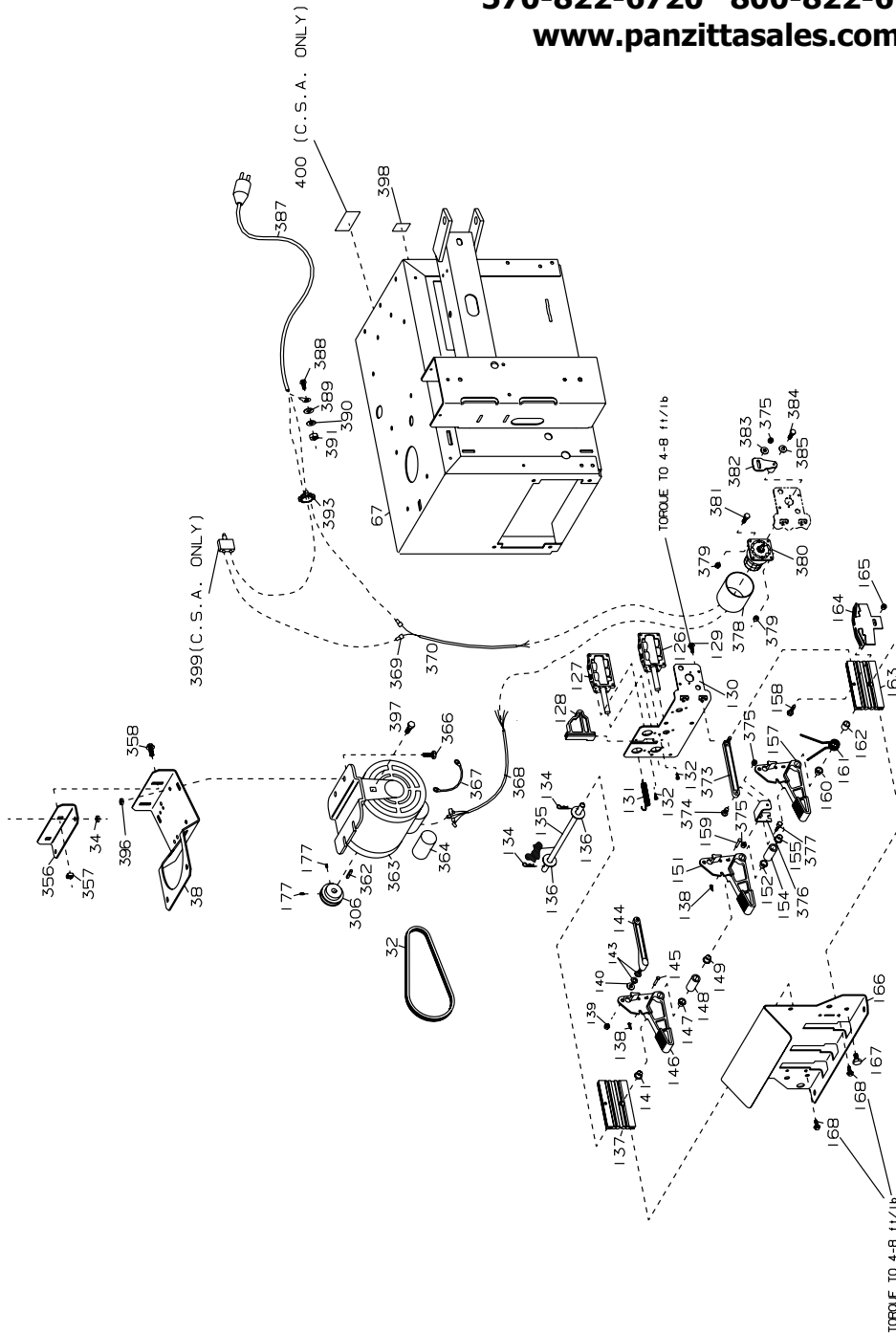

ELECTRIC MOTOR MODELS

Part No.	Description	Ref	Part No.	Description	Ref	Part No.	Description
369	Wire Joint	382	181728	Switch Actuator Lever	393	150128	1/2" Cable Connector
370	Cord - Entrance to Switch	383	000745	Ø1/4" Flat Washer	396	181183	Nut-Nyl. Ins. Lk., 5/16-18 Gr.5
373	Switch Lever Assembly	384	181982	3MM x 12mm Gr.5 Hex Hd. Cap Scr.	397	120455	#10-24 Gr.2 Self Tapping Screw
374	Shoulder - Screw, 5/16	385	301072	#6 Internal Tooth Lock Washer	398	180237	Caution Decal
375	1/4-20 Gr.5 Nylon Insert Lock Nut	387	181956	Power Cable Assy. - 115V	399	181587	Circuit Breaker (C.S.A.)
376	Sw. Pedal Lever Spacer (RED)	182257	Power Cable Assy. - 115V (C.S.A)	400	140963	Decal - Elect. Caution (C.S.A.)	
377	Screw - Hex Hd., 1/4-20 x 1.00 Gr.5	182712	Power Cable Assy. - 220V 50Hz 1Ø	401	182960	Mount/Demount Head (PLASTIC)	
378	Switch Cover	106301	1/4-20 Gr.5 Hex Hd. Self Tap. Scr.	402	183033	Washer	
379	#10-24 Gr.5 Nylon Insert Lock Nut	150441	1/4" Star Lock Washer	403	183881	Nylon Tube 3/8" x 7"	
380	Reversing Switch	301142	1/4" Spring Lock Washer				
381	#10-24 x 5/8" Gr.8 Bt.Hd.Skt.Cap Scr.	107440	1/4-20 Gr.5 Hex Nut				

WIRING DIAGRAMS

DOMESTIC

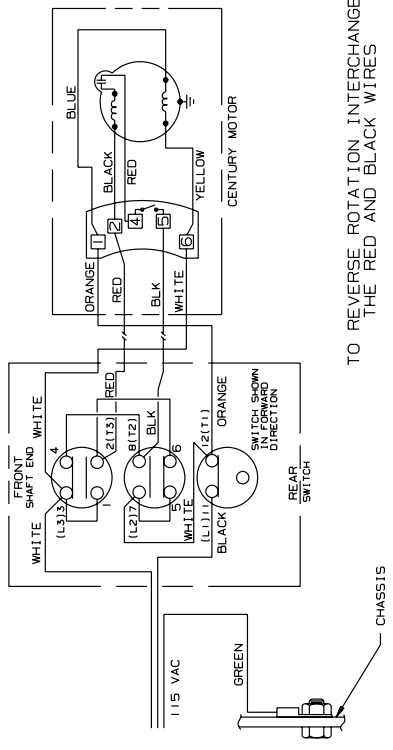

TO REVERSE ROTATION, INTERCHANGE THE RED AND BLACK WIRES

EXPORT

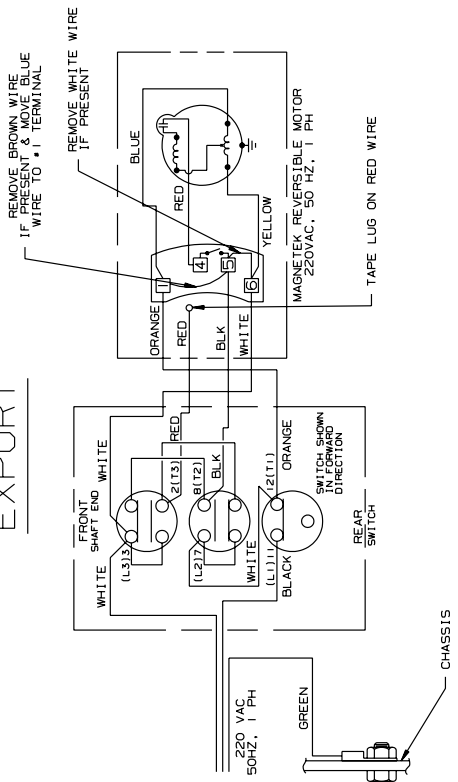

TO REVERSE ROTATION, INTERCHANGE THE RED AND BLACK WIRES

C.S.A.

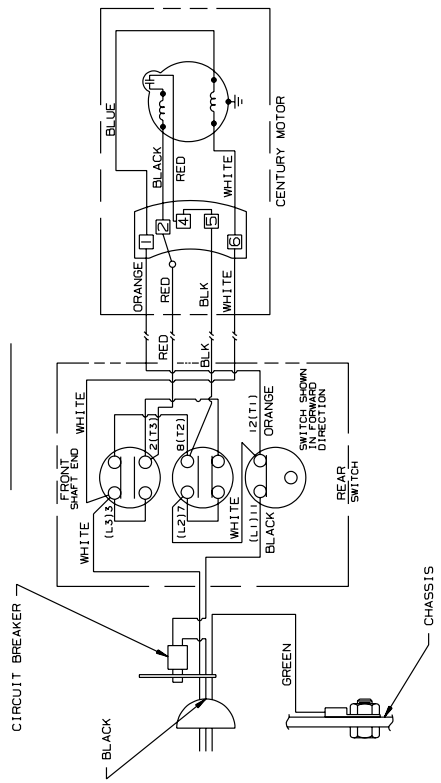

TO REVERSE ROTATION, INTERCHANGE THE RED AND BLACK WIRES

PANZITTA SALES & SERVICE
72 George Avenue
Wilkes-Barre, PA 18705
570-822-6720 800-822-6720
www.panzittasales.com

Rim Clamp® Tire Changer

All-Air Unit Compressed Air Requirements

COATS® Rim Clamp® tire changers that are powered entirely by air (no electric motor) require a single compressed air power source. Refer to the table below for exact specifications.

Tire Changer Model	Compressor Size	Capable of
RC100	5 HP	5 SCFM at 150 PSI

Oiler and Water Separator Maintenance

The oiler and water separator (on units so equipped) require weekly service. Oil and water levels (indicated on the level gauge on the side of each bowl) should be checked regularly

1. On units without automatic drain (manufactured before August 1996), drain the water from the separator by unscrewing the petcock on the bottom of the bowl. Allow water to drain and tighten petcock securely by hand.

2. Add oil to the oiler if the fluid level is more than 1/4" from the top of the gauge. Remove the filler plug in the top of the oiler, and add SAE 10W non-detergent oil or an air tool oil to bring the level up to 1/4" from the top of the gauge. Replace the filler plug and clean up any spilled oil.

3. On units manufactured before August 1996, adjust the oil flow by pulling the red flow adjustment ring up and turning it to increase or decrease the flow. Push the ring down to lock. Watch the formation of oil drops in the see-through oil chamber. Continually cycle the bead loosener through full strokes and count the drops during the cycles. The delivery of oil to the air line should be about 1 drop per 10 cylinder cycles. Adjust the flow as required.

Note: Some older unit may use an adjustment screw on top of the oiler instead of the red ring and see-through chamber. To adjust these units, turn the screw fully clockwise to stop the flow, then turn it back counterclockwise 1/4 turn. Units manufactured after August 1996 are factory pre-set and require no adjustment.

Transmission Lubrication

Check the fluid level in the tabletop transmission with the oil check dipstick. If fluid shows on the dipstick, it is properly filled. If no fluid is present on the dipstick, add a high quality SAE 80/90 gear lubricant. Add lubricant and check the level. Stop adding lubricant when it shows on the dipstick.

Air Gauge Check and Recalibration

1. Inflate a standard 15" passenger car tire/wheel assembly to 32 PSI. Use a high quality stick-type pressure gauge to verify the pressure. Attach the tire changer's inflation hose to the valve stem and check the pressure reading on the air gauge. If it does not read 32 PSI, recalibrate the gauge.

2. Remove the screw-on lens. Loosen the 2 screws on the face of the gauge. Loosen them just enough so that the gauge face moves. Do not remove the screws.

3. Rotate the gauge face until the 32 PSI mark is aligned with the gauge needle. Tighten the 2 screws and replace the lens.

Danger, Warning, Caution, and Instructional Decals

Always make the cleaning of these important decals a part of your regular maintenance routine. If they are damaged or illegible, replace them immediately. Your safety, and the safety of others is involved!

PANZITTA SALES & SERVICE
72 George Avenue
Wilkes-Barre, PA 18705
570-822-6720 800-822-6720
www.panzittasales.com