

COATS®

1175 Wheel Balancer



PANZITTA SALES & SERVICE
72 George Avenue
Wilkes-Barre, PA 18705
570-822-6720 800-822-6720
www.panzittasales.com

Parts Identification

READ these instructions before placing unit in service KEEP these and other materials delivered with the unit in a binder near the machine for ease of reference by supervisors and operators.

HENNESSY INDUSTRIES, INC.

HENNESSY INDUSTRIES INC. Manufacturer of AMMCO®, COATS® and BADA® Automotive Service Equipment and Tools.

Manual Part No.: 85008896 00
Revision: 11/07

Parts Identification

The following pages include parts breakdowns with exploded view illustrations to help with ordering replacement or spare kits. Assemblies are noted where it is recommended that individual parts not be ordered separately. Every effort is made to supply accurate exploded views, however, due to interim changes in manufacturing operations, some units may not be exactly as illustrated.

Chassis Assembly

ITEM	PART NO.	DESCRIPTION
1	85008973	Cover with Weight Tray
5	85008974	Chassis
7	85008975	Peg Bracket
9	85008957	Plug

PANZITTA SALES & SERVICE
72 George Avenue
Wilkes-Barre, PA 18705
570-822-6720 800-822-6720
www.panzittasales.com

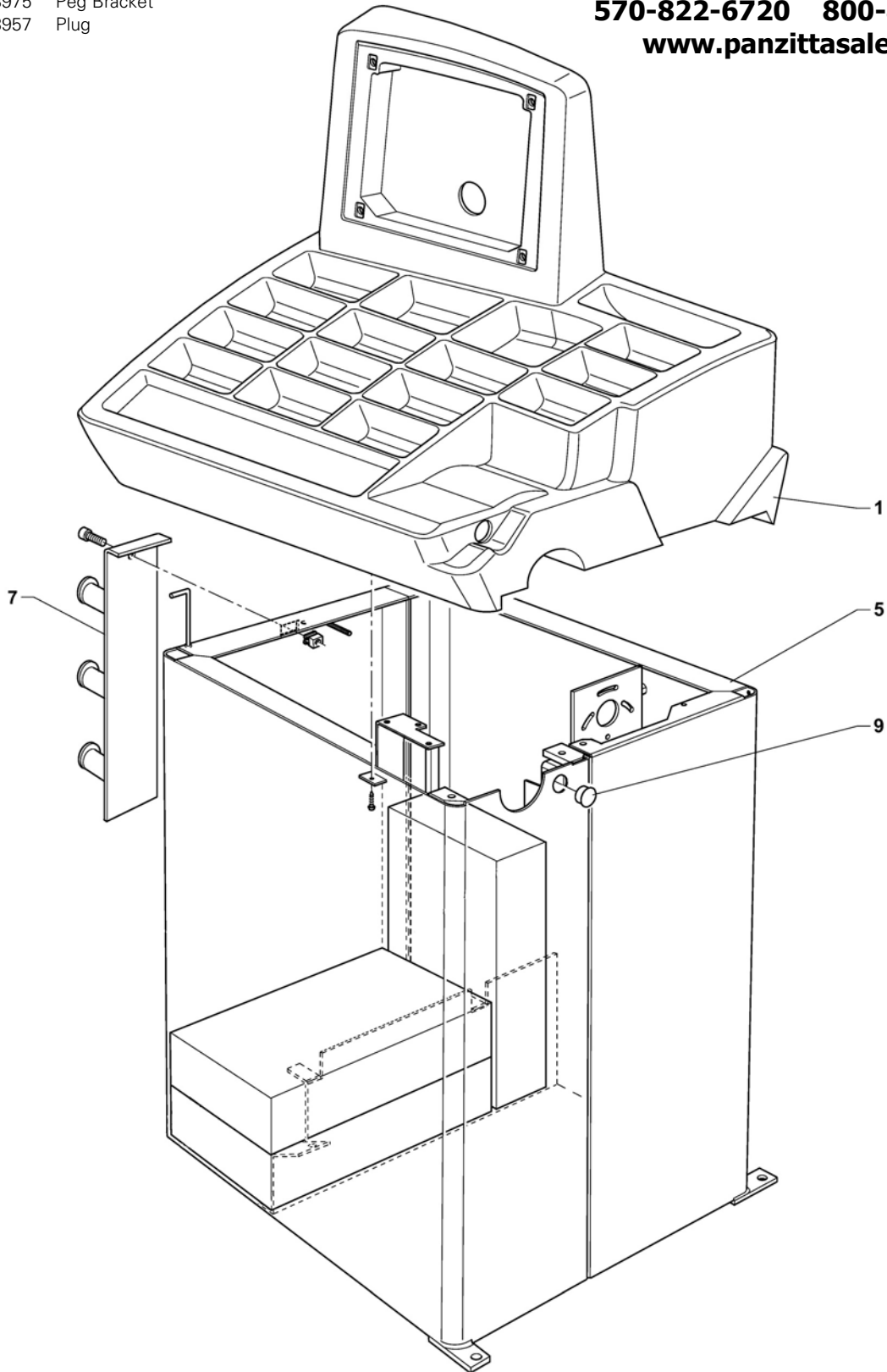

Motor & Piezo Assembly

PANZITTA SALES & SERVICE

72 George Avenue
 Wilkes-Barre, PA 18705
 570-822-6720 800-822-6720
 www.panzittasales.com

ITEM	DESCRIPTION
------	-------------

- | | | |
|-----|----------|------------------|
| P/N | 85008927 | 230V Motor w/Key |
| 12 | | 230V Motor |
| 13 | | Motor Key |

P/N	85008980	230V Motor Assembly
-----	----------	---------------------

- | | | |
|----|--|---------------|
| 11 | | Screw |
| 12 | | 230V Motor |
| 13 | | Motor Key |
| 14 | | Drive Pulley |
| 15 | | Flat Washer |
| 16 | | Screw |
| 17 | | Spring Washer |
| 19 | | Drive Belt |

P/N	85008983	Piezo Kit
-----	----------	-----------

- | | | |
|----|--|----------------|
| 22 | | Piezo Assembly |
| 27 | | Piezo Assembly |

P/N	85008984	Piezo w/connectors Kit
-----	----------	------------------------

- | | | |
|----|--|----------------|
| 20 | | Flat Washer |
| 21 | | Hex Nut |
| 22 | | Piezo Assembly |
| 23 | | Cup Spring |
| 24 | | Flat Washer |
| 25 | | Threaded Bar |
| 26 | | Eye Rod |
| 27 | | Piezo Assembly |

PART

ITEM	NO.	DESCRIPTION
1	85008953	Compl. Position Pick Up
5	85008910	Position Pick Up Board
19	85008905	Drive Belt
28	85008979	Spacer No BP

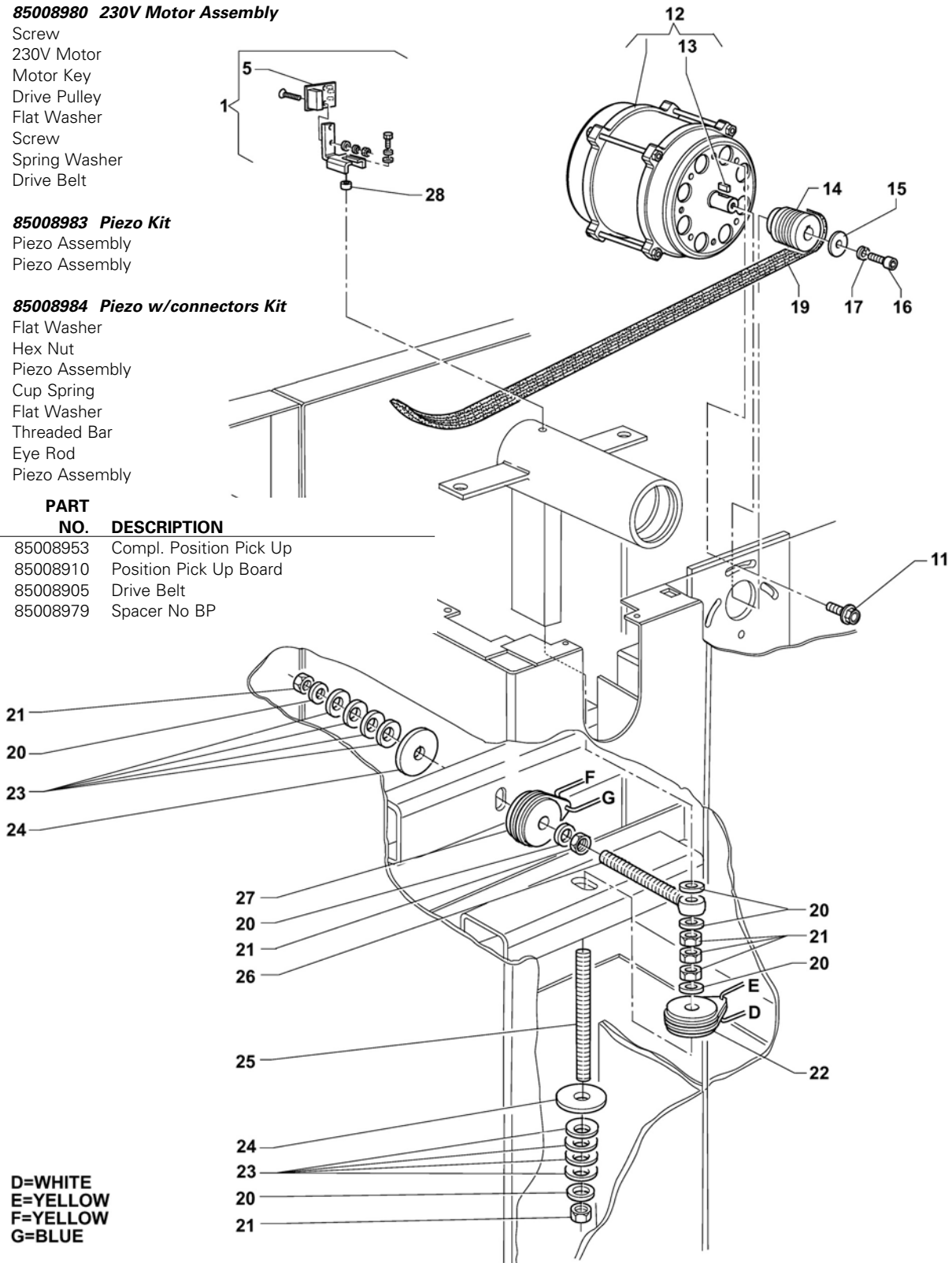

Shaft Assembly

ITEM	PART NO.	DESCRIPTION
4	85008949	Drive Pulley
5	85008950	Encoder Phase Disc
7	85008914	Bearing
8	85008976	Leaf Spring Set
9	8110241	Weight Position Decal
16	85009009	40mm Shaft
18	85008951	Spring Cover
19	85008915	Spring Shaft Assembly

PANZITTA SALES & SERVICE
72 George Avenue
Wilkes-Barre, PA 18705
570-822-6720 800-822-6720
www.panzittasales.com

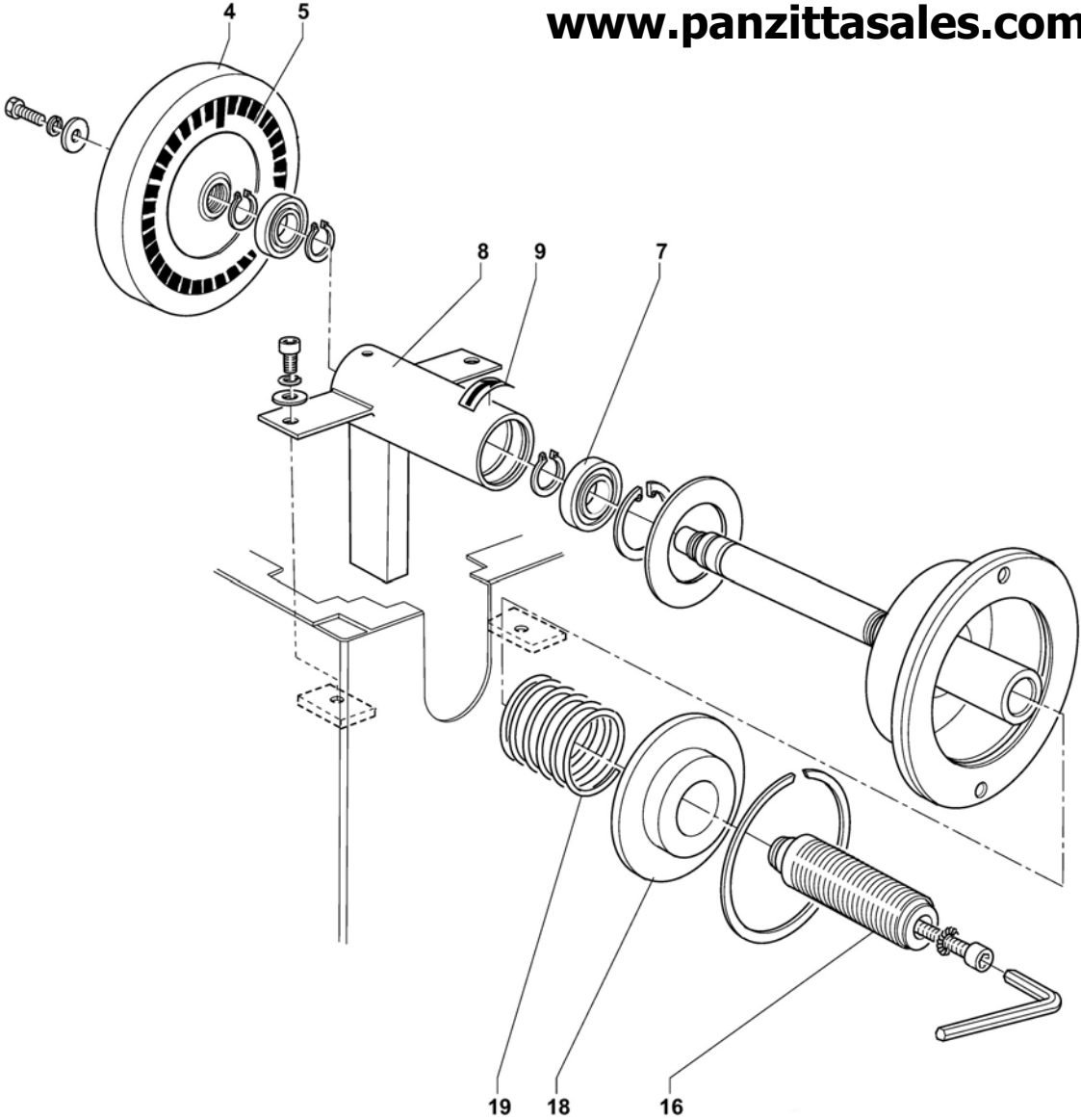

Touch Panel Assembly

ITEM	DESCRIPTION
P/N	85008977 Touch Panel Assembly
2	Screw
4	230V Motor
5	Motor Key
6	Drive Pulley
7	Flat Washer
8	Screw

ITEM	PART NO.	DESCRIPTION
3	85008924	Computer Board

PANZITTA SALES & SERVICE
72 George Avenue
Wilkes-Barre, PA 18705
570-822-6720 800-822-6720
www.panzittasales.com

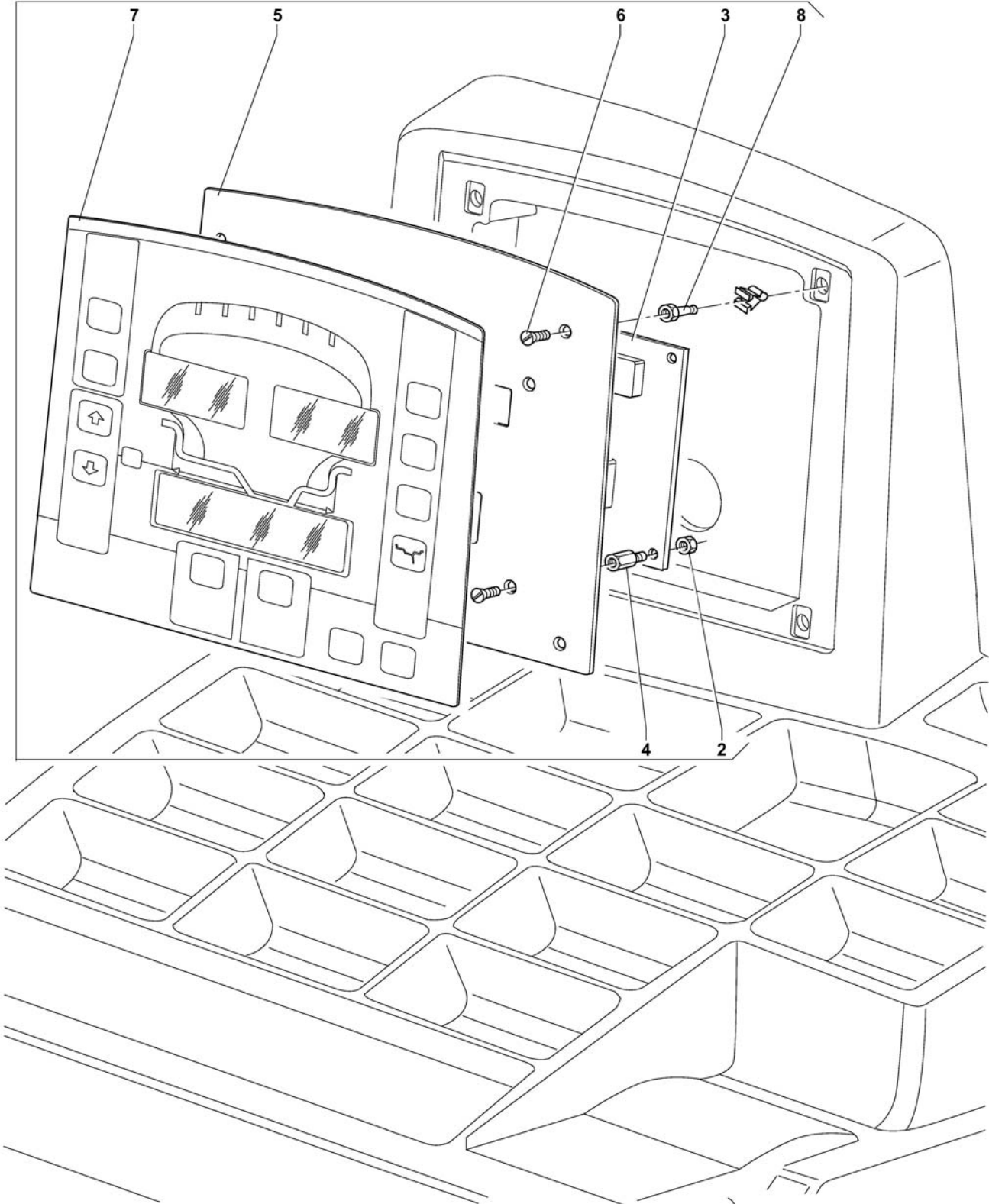

Distance Guage

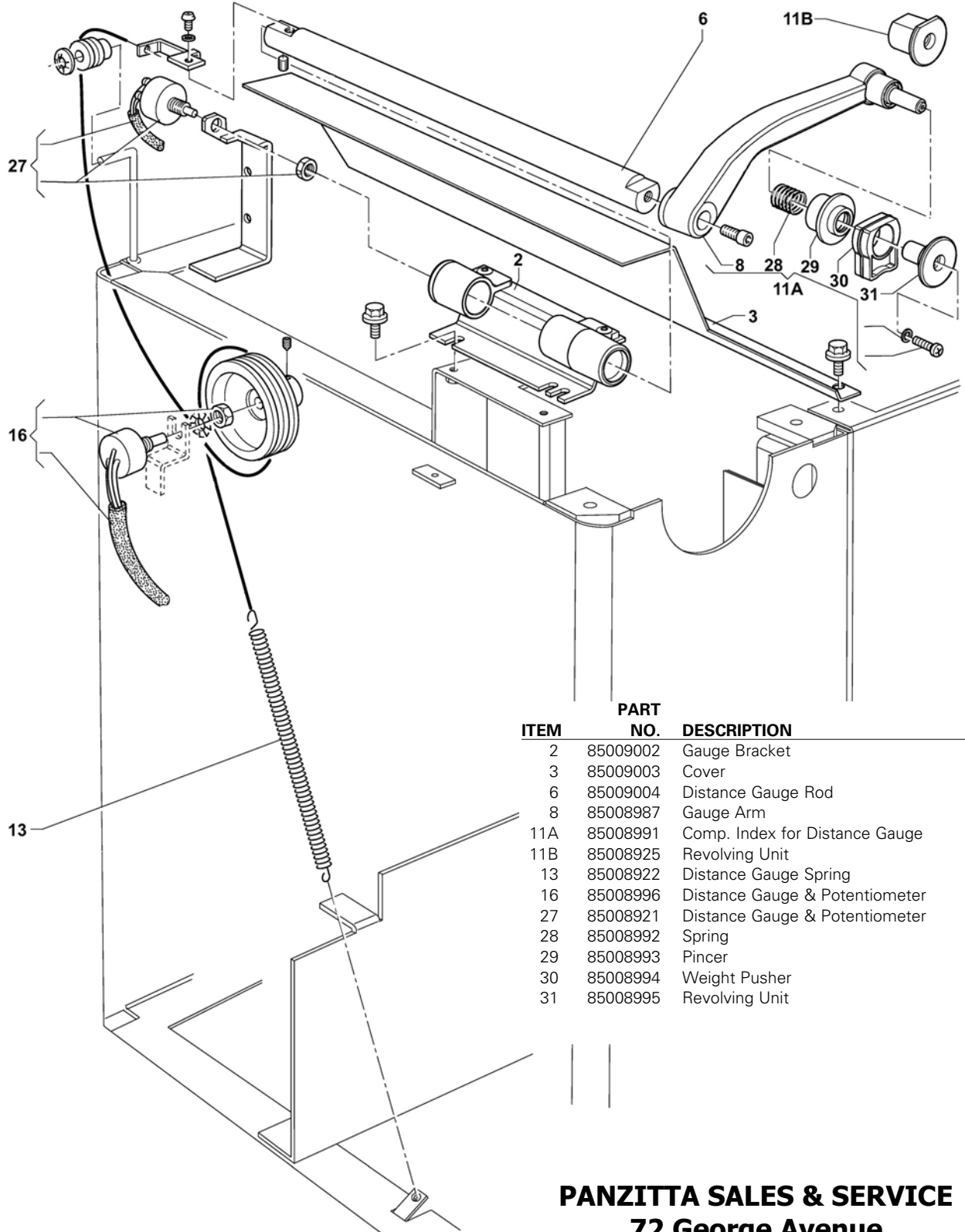

ITEM	PART NO.	DESCRIPTION
2	85009002	Gauge Bracket
3	85009003	Cover
6	85009004	Distance Gauge Rod
8	85008987	Gauge Arm
11A	85008991	Comp. Index for Distance Gauge
11B	85008925	Revolving Unit
13	85008922	Distance Gauge Spring
16	85008996	Distance Gauge & Potentiometer
27	85008921	Distance Gauge & Potentiometer
28	85008992	Spring
29	85008993	Pincer
30	85008994	Weight Pusher
31	85008995	Revolving Unit

PANZITTA SALES & SERVICE
72 George Avenue
Wilkes-Barre, PA 18705
570-822-6720 800-822-6720
www.panzittasales.com

Power Panel

PANZITTA SALES & SERVICE
72 George Avenue
Wilkes-Barre, PA 18705
570-822-6720 800-822-6720
www.panzittasales.com

ITEM	PART NO.	DESCRIPTION
3	85009005	Power Plate Kit
6	85008929	Power Supply Board 230V
8	85008928	Capacitor 230V
9	85009001	Cable Circlip
*	85008947	RC Filter/Snubber

*Not Shown

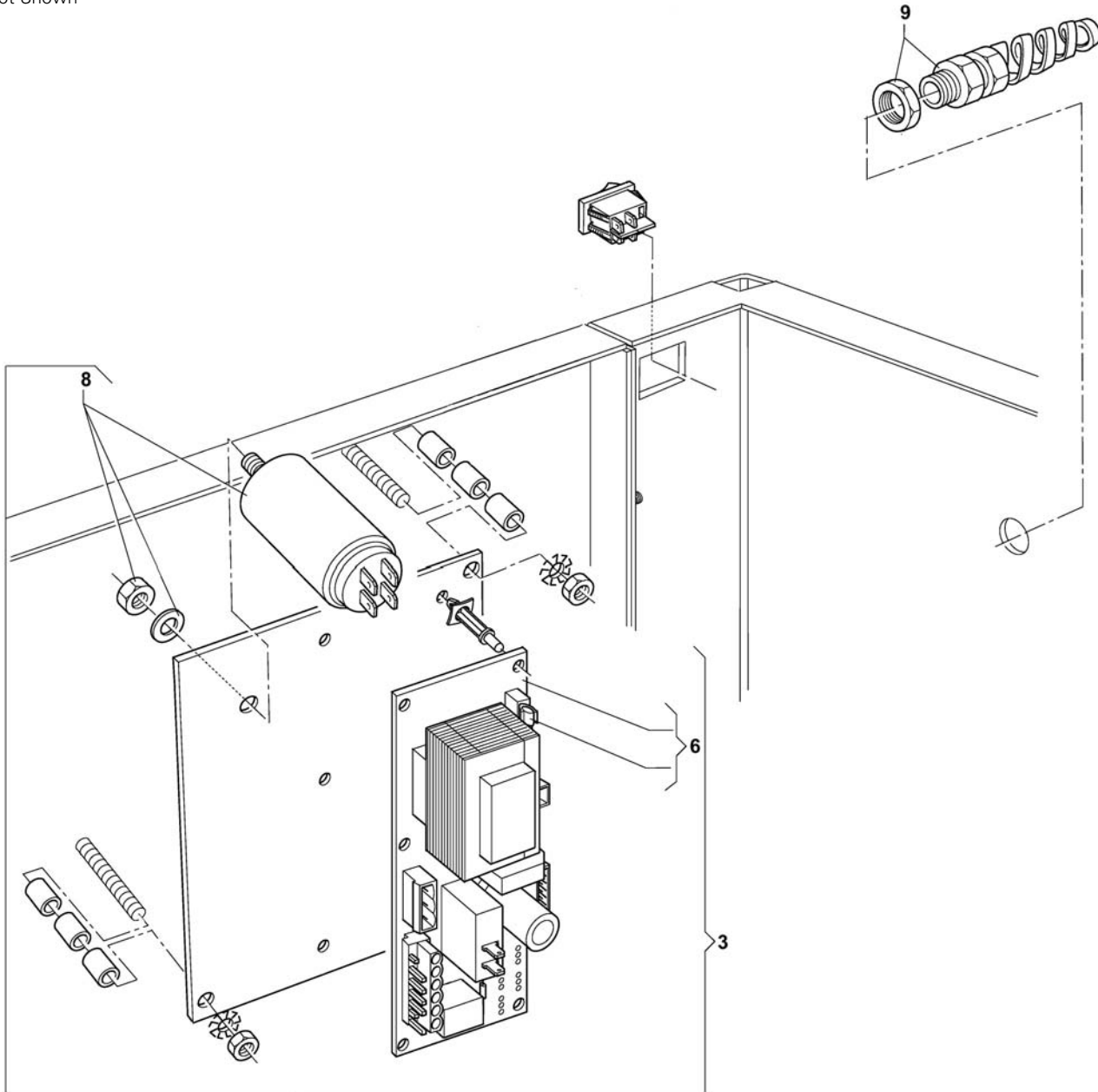

Wheel Guard

ITEM	DESCRIPTION
<i>P/N</i> 85008954	Wheel Guard
8	Wheel Guard
9	Self-threading Screw
11	Tube Chassis

ITEM	PART NO.	DESCRIPTION
1	85008968	Plug
3	85008967	Stop Ring
4	85009024	Bush
5	85008969	Support
10	85008971	Spring
16	85008911	Cable w/microswitch
17	85008972	Microswitch

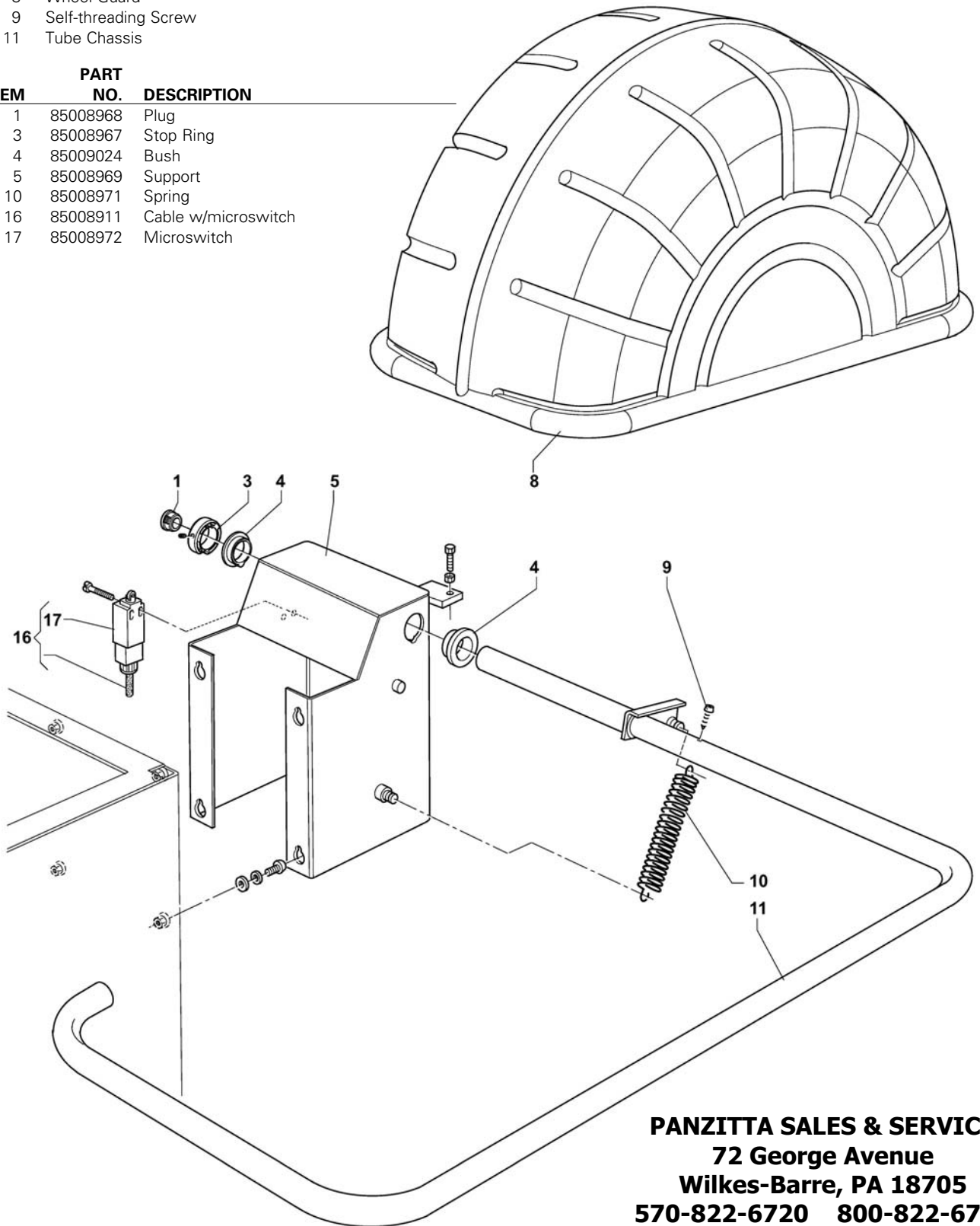

PANZITTA SALES & SERVICE
72 George Avenue
Wilkes-Barre, PA 18705
570-822-6720 800-822-6720
www.panzittasales.com

Harnesses

ITEM	PART NO.	DESCRIPTION
*	85008908	Hood Switch Harness
*	85008919	Encoder Cable
*	85008923	Display Power Ribbon
*	85008926	Ground Cable For Display
*	85009007	Power Cord from Wall, 1175
*	85009008	Cord from Switch to MCB
*	85009025	Piezo/Display Cable

*Not Shown

PANZITTA SALES & SERVICE
72 George Avenue
Wilkes-Barre, PA 18705
570-822-6720 800-822-6720
www.panzittasales.com