

COATS®

775/875 Wheel Balancer

PANZITTA SALES & SERVICE
72 George Avenue
Wilkes-Barre, PA 18705
570-822-6720 800-822-6720
www.panzittasales.com



Parts Identification

READ these instructions before placing unit in service KEEP these and other materials delivered with the unit in a binder near the machine for ease of reference by supervisors and operators.

HENNESSY INDUSTRIES, INC.

HENNESSY INDUSTRIES INC. Manufacturer of AMMCO®, COATS® and BADA® Automotive Service Equipment and Tools.

Manual Part No.: 85008895 00

Revision: 11/07

Parts Identification

The following pages include parts breakdowns with exploded view illustrations to help with ordering replacement or spare kits. Assemblies are noted where it is recommended that individual parts not be ordered separately. Every effort is made to supply accurate exploded views, however, due to interim changes in manufacturing operations, some units may not be exactly as illustrated.

Shaft Assembly

ITEM	PART NO.	DESCRIPTION
4	85008949	Drive Pulley
5	85008950	Encoder Phase Disc
7	85008914	Bearing
8	85008976	Leaf Spring Set
9	8110241	Weight Position Decal
16	85009009	40mm Shaft
18	85008951	Spring Cover
19	85008915	Spring Shaft Assembly

PANZITTA SALES & SERVICE
72 George Avenue
Wilkes-Barre, PA 18705
570-822-6720 800-822-6720
www.panzittasales.com

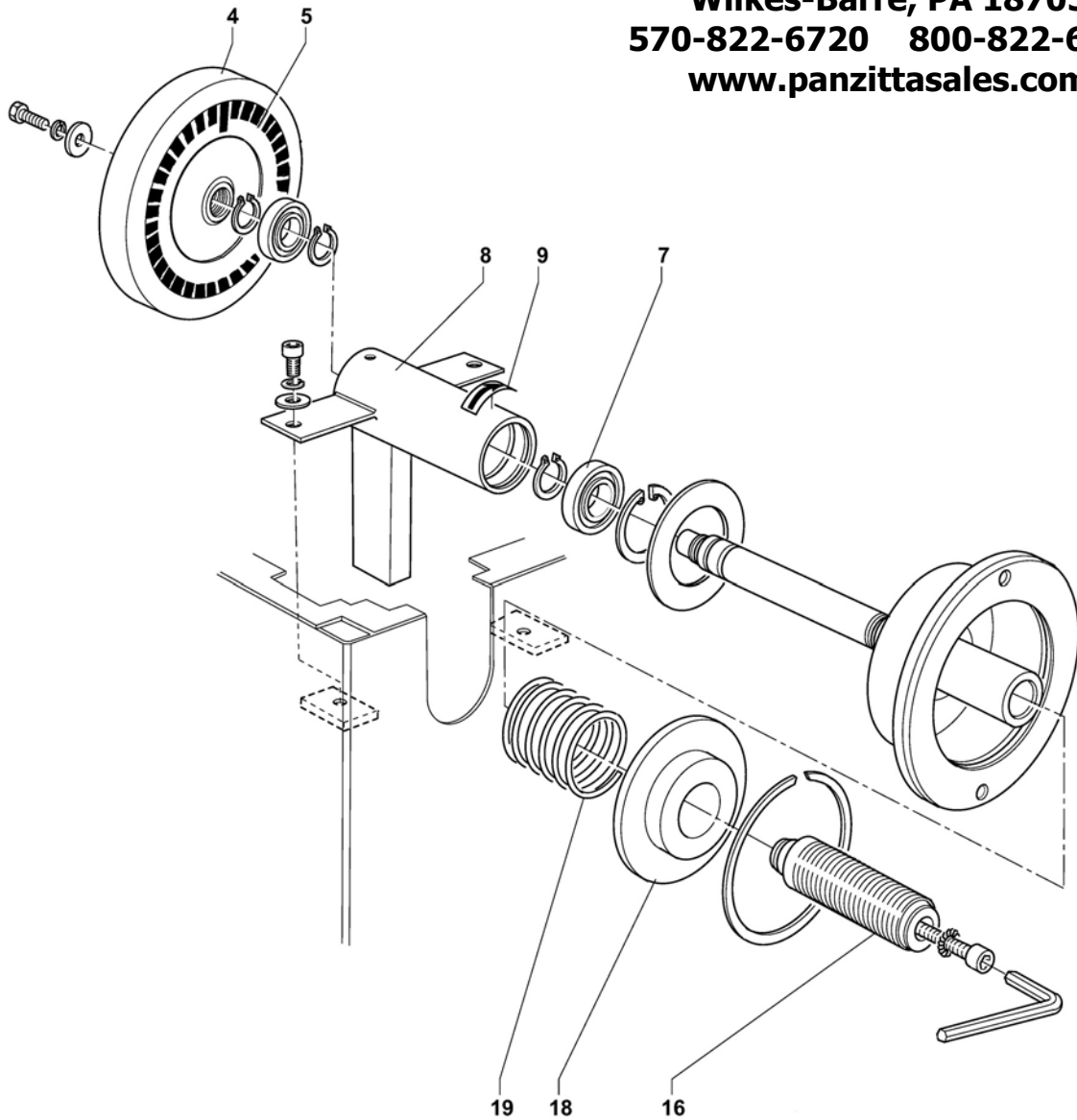

Motor & Piezo Assembly

ITEM DESCRIPTION

P/N 85008954 115V Motor Assembly

- 11 Screw
- 12 115V Motor
- 13 Motor Key
- 14 Drive Pulley
- 15 Flat Washer
- 16 Screw
- 17 Spring Washer
- 19 Drive Belt

P/N 85008983 Piezo Kit

- 22 Piezo Assembly
- 27 Piezo Assembly

P/N 85008984 Piezo w/connectors Kit

- 20 Flat Washer
- 21 Hex Nut
- 22 Piezo Assembly
- 23 Cup Spring
- 24 Flat Washer
- 25 Threaded Bar
- 26 Eye Rod
- 27 Piezo Assembly

PART NO. DESCRIPTION

- 1 85008953 Compl. Position Pick Up
- 5 85008910 Position Pick Up Board
- 12 85008913 115V Motor
- 19 85008905 Drive Belt
- 28 85008979 Spacer No BP

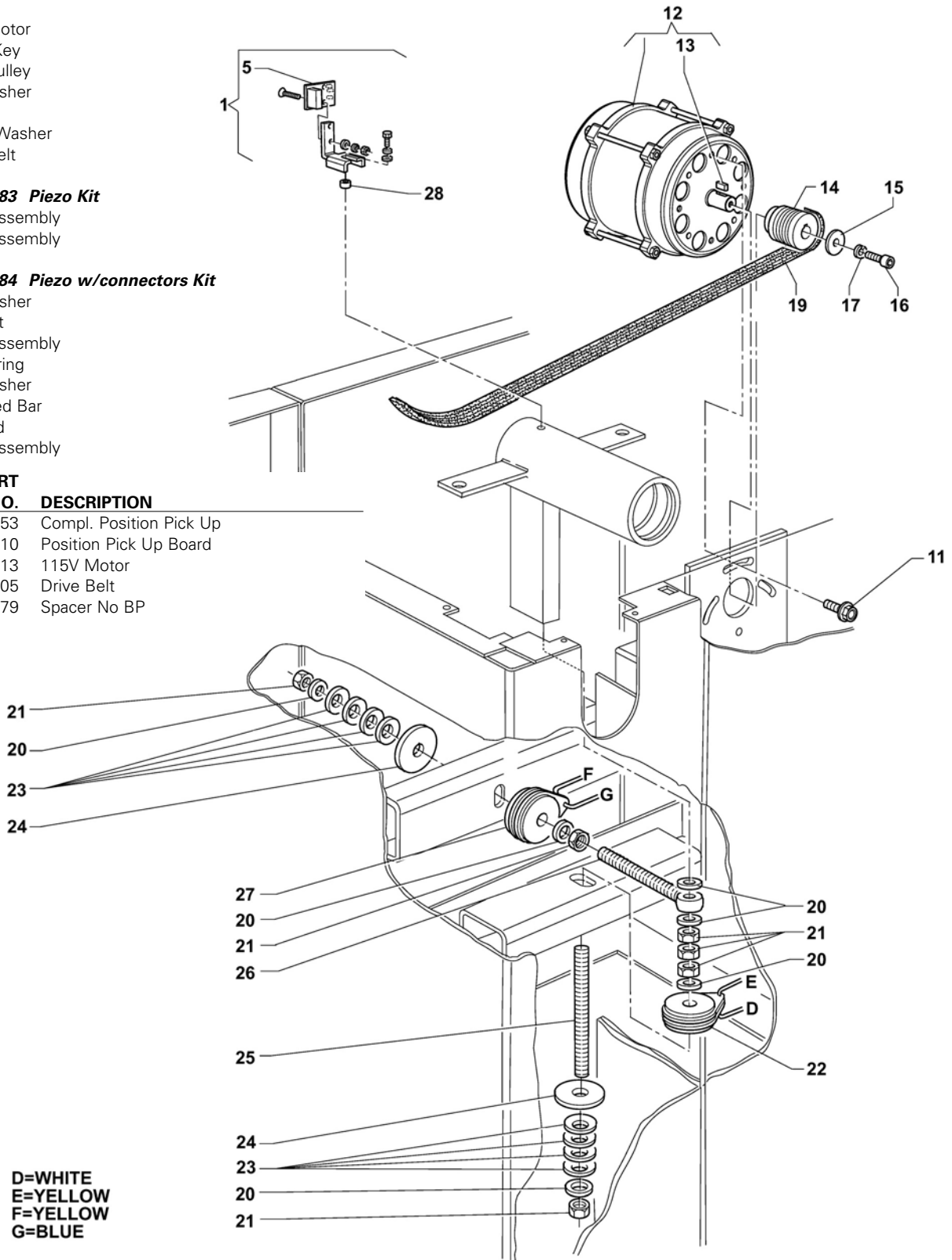

PANZITTA SALES & SERVICE
72 George Avenue
Wilkes-Barre, PA 18705
570-822-6720 800-822-6720
www.panzittasales.com

Chassis & Touch Panel Assembly (875)

ITEM	DESCRIPTION
<i>P/N</i> 85008964	<i>Touch Panel Assembly</i>
2	Panel Support
3	Control Panel
4	Screw
5	Spacer
7	Rapid Pin
8	Nut

ITEM	PART NO.	DESCRIPTION
6	85008920	Computer Board
10	85008965	Cover w/Weight Tray
12	85008966	Base Plate

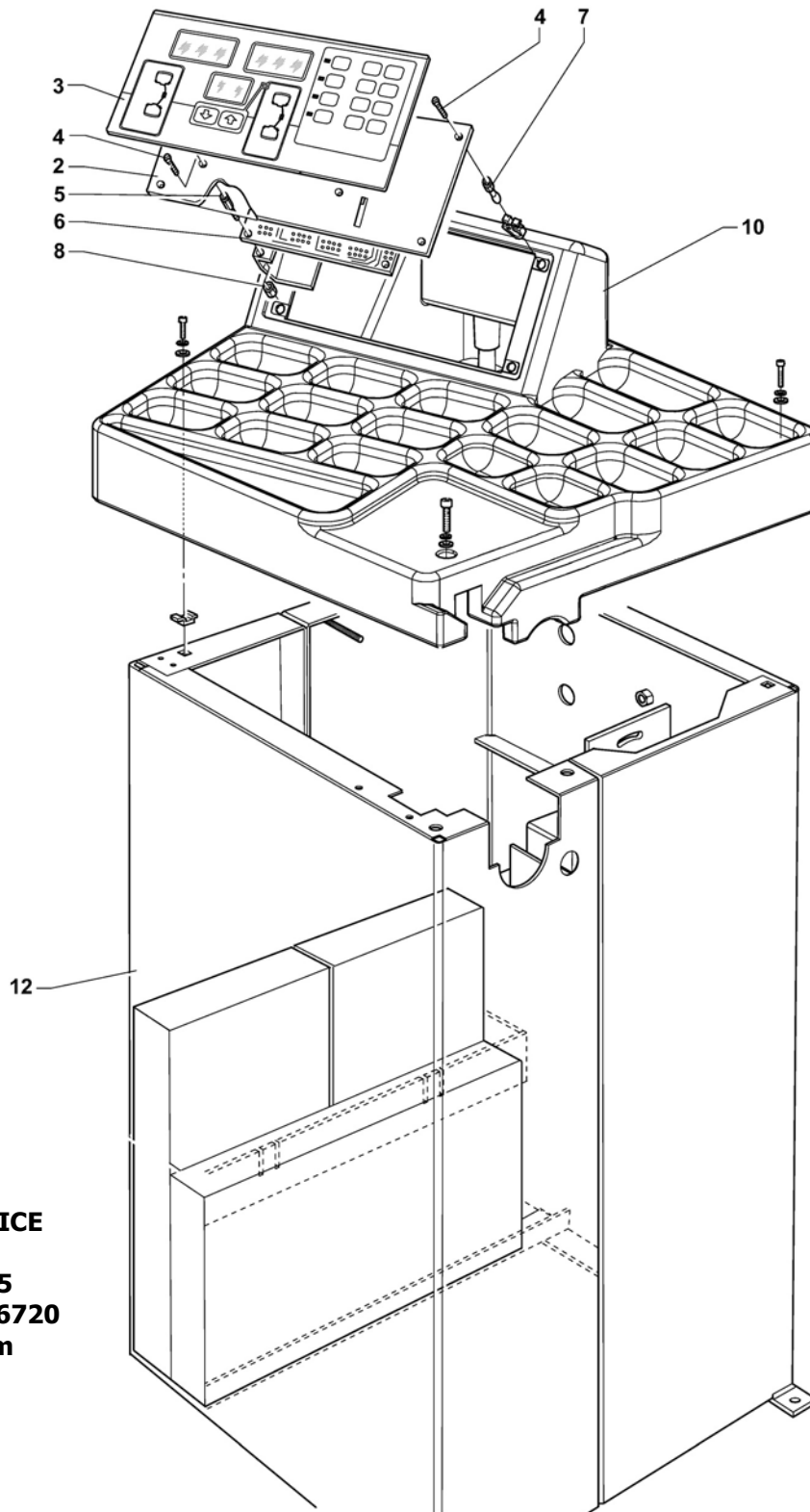

PANZITTA SALES & SERVICE
 72 George Avenue
 Wilkes-Barre, PA 18705
 570-822-6720 800-822-6720
www.panzittasales.com

Touch Panel Assembly (775)

ITEM	PART NO.	DESCRIPTION
1	85008948	Touch Panel Assembly
3	85008909	Computer Board
10	85008912	Fuse

PANZITTA SALES & SERVICE
72 George Avenue
Wilkes-Barre, PA 18705
570-822-6720 800-822-6720
www.panzittasales.com

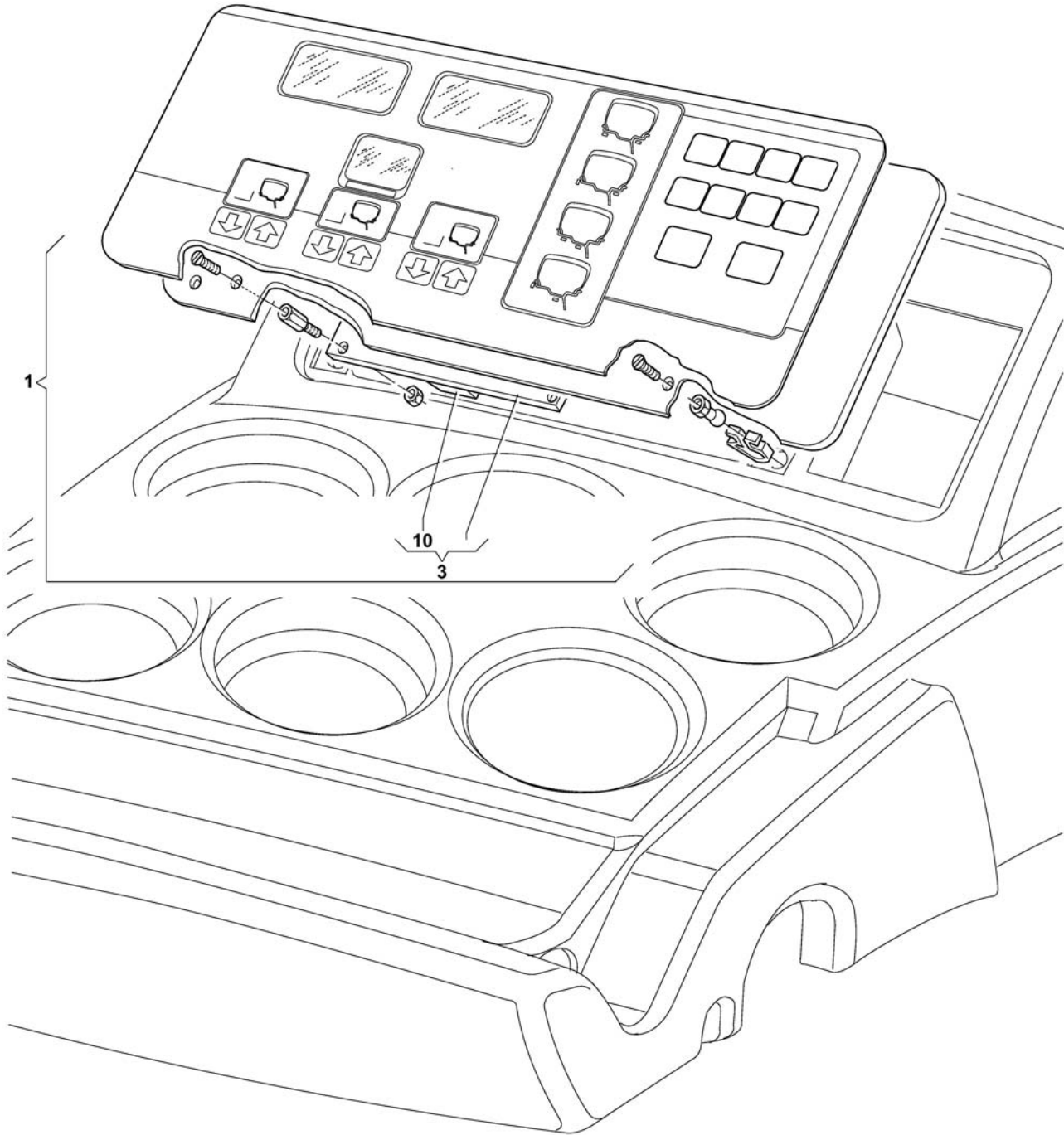

Chassis Assembly (775)

ITEM	PART NO.	DESCRIPTION
1	85008955	Cover with Weight Tray
2	85008956	Rear Casing
3	85009957	Plug
5	85008958	Casing
6	85008959	Front Casing

PANZITTA SALES & SERVICE
72 George Avenue
Wilkes-Barre, PA 18705
570-822-6720 800-822-6720
www.panzittasales.com

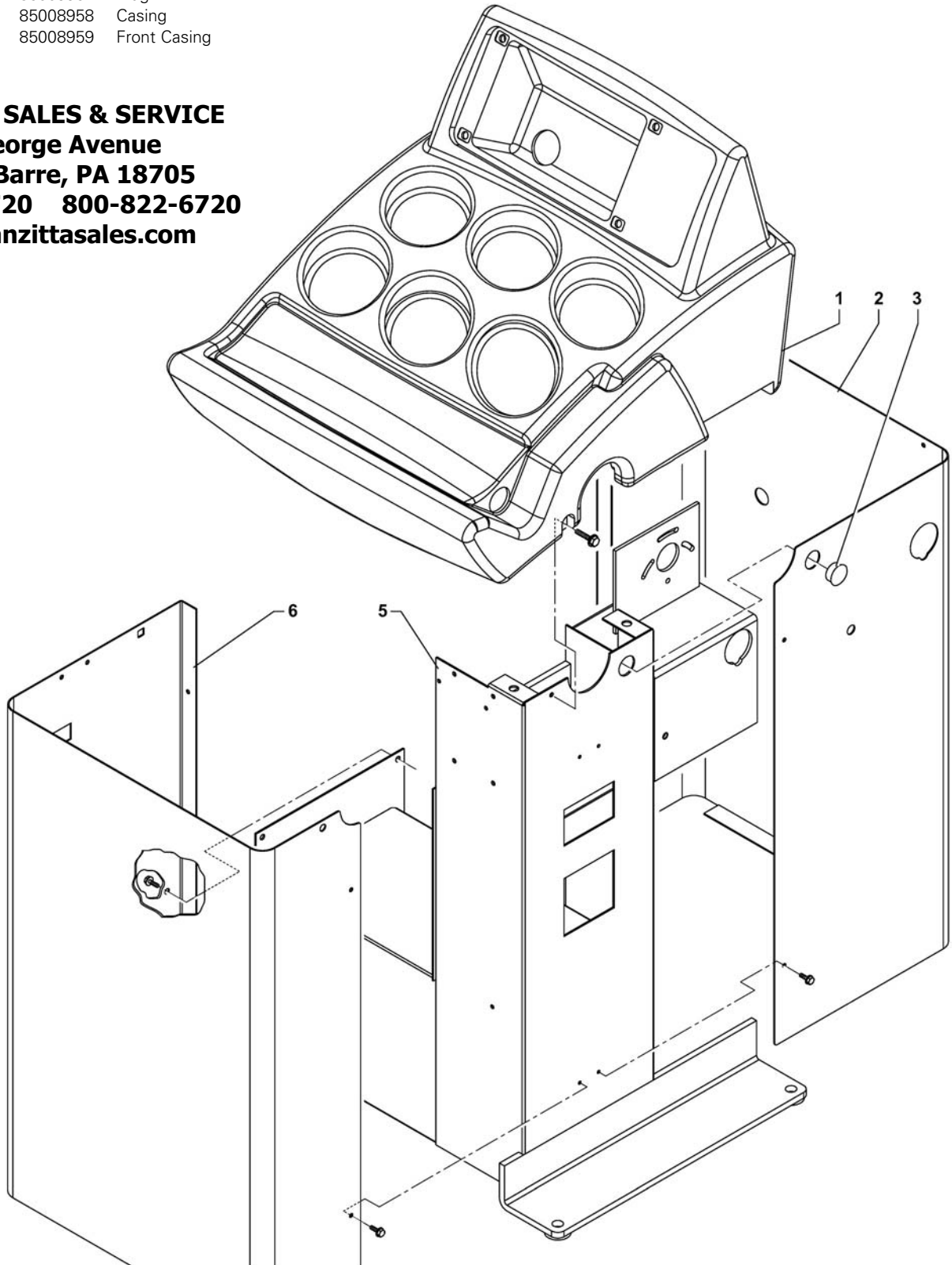

Distance Guage (875)

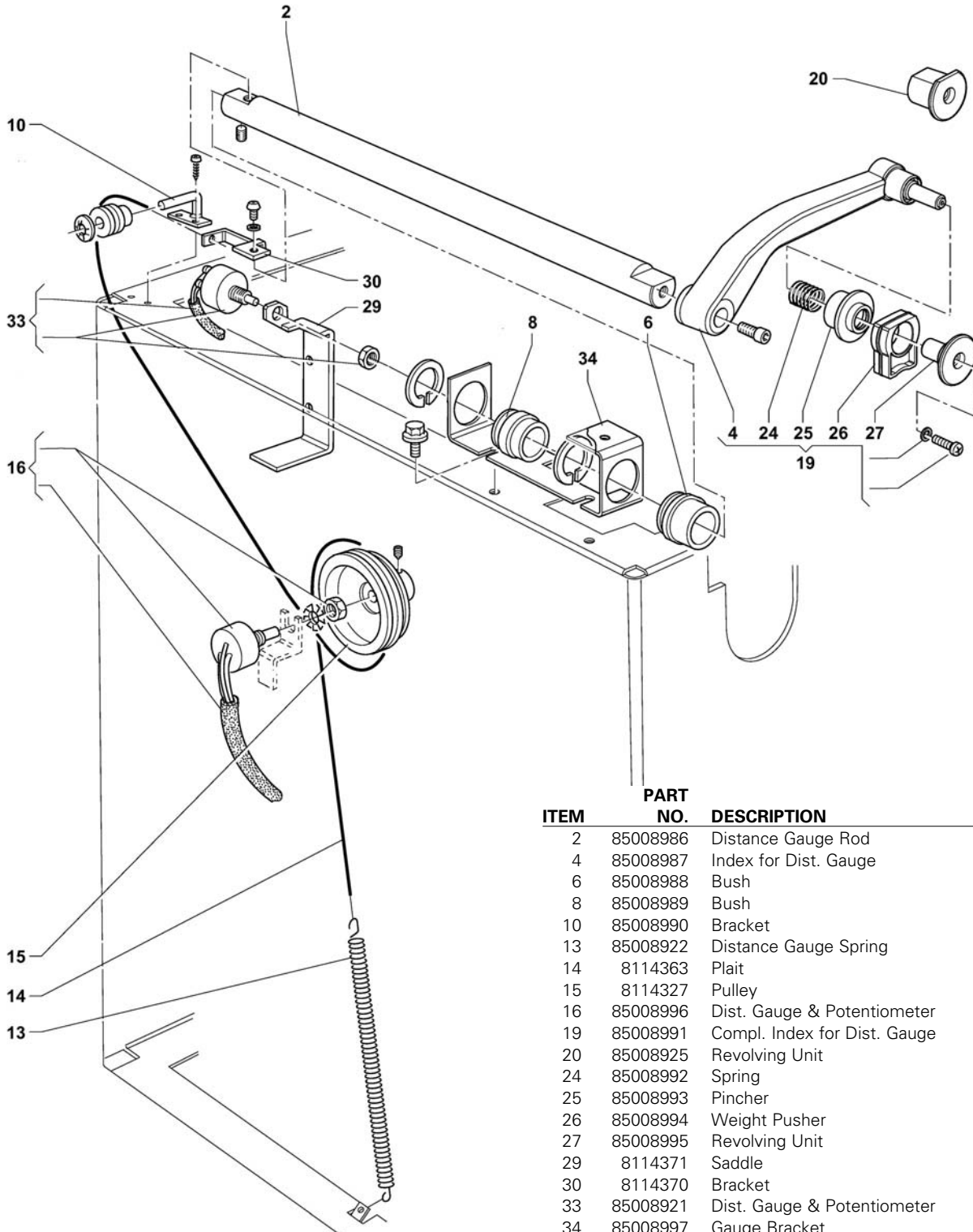

ITEM	PART NO.	DESCRIPTION
2	85008986	Distance Gauge Rod
4	85008987	Index for Dist. Gauge
6	85008988	Bush
8	85008989	Bush
10	85008990	Bracket
13	85008922	Distance Gauge Spring
14	8114363	Plait
15	8114327	Pulley
16	85008996	Dist. Gauge & Potentiometer
19	85008991	Compl. Index for Dist. Gauge
20	85008925	Revolving Unit
24	85008992	Spring
25	85008993	Pincher
26	85008994	Weight Pusher
27	85008995	Revolving Unit
29	8114371	Saddle
30	8114370	Bracket
33	85008921	Dist. Gauge & Potentiometer
34	85008997	Gauge Bracket

PANZITTA SALES & SERVICE
72 George Avenue
Wilkes-Barre, PA 18705
570-822-6720 800-822-6720
www.panzittasales.com

PANZITTA SALES & SERVICE

72 George Avenue

Wilkes-Barre, PA 18705

570-822-6720 800-822-6720

www.panzittasales.com

Distance Guage (775)

ITEM	PART NO.	DESCRIPTION
1	85008906	Distance Gauge Spring
2	85008952	Distance Gauge Rod
3	85008960	Elastic Dowel
4	85008961	Gauge Bracket
5	85008962	Graduated Band
8	85008963	Index for Distance Guage

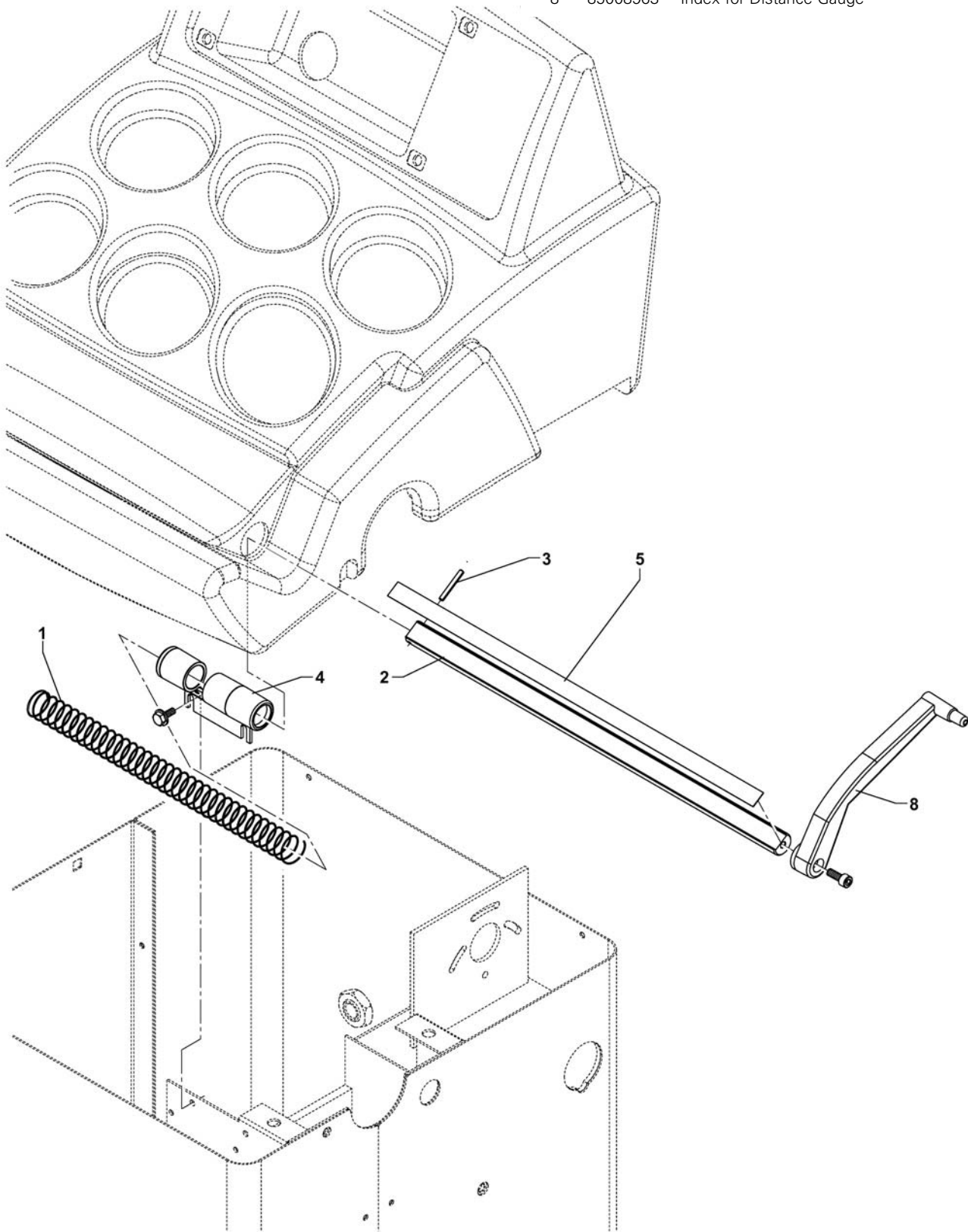

Power Panel (875)

ITEM	PART NO.	DESCRIPTION
1	85008907	Platform Switch
2	85008998	Spacer
3	85008999	Power Plate Kit
4	85009000	Electric Plate
6	85008917	Power Supply Board 230V
8	85008918	Capacitor 230V
9	85009001	Cable Circlip
*	85008947	RC Filter/Snubber

*Not Shown

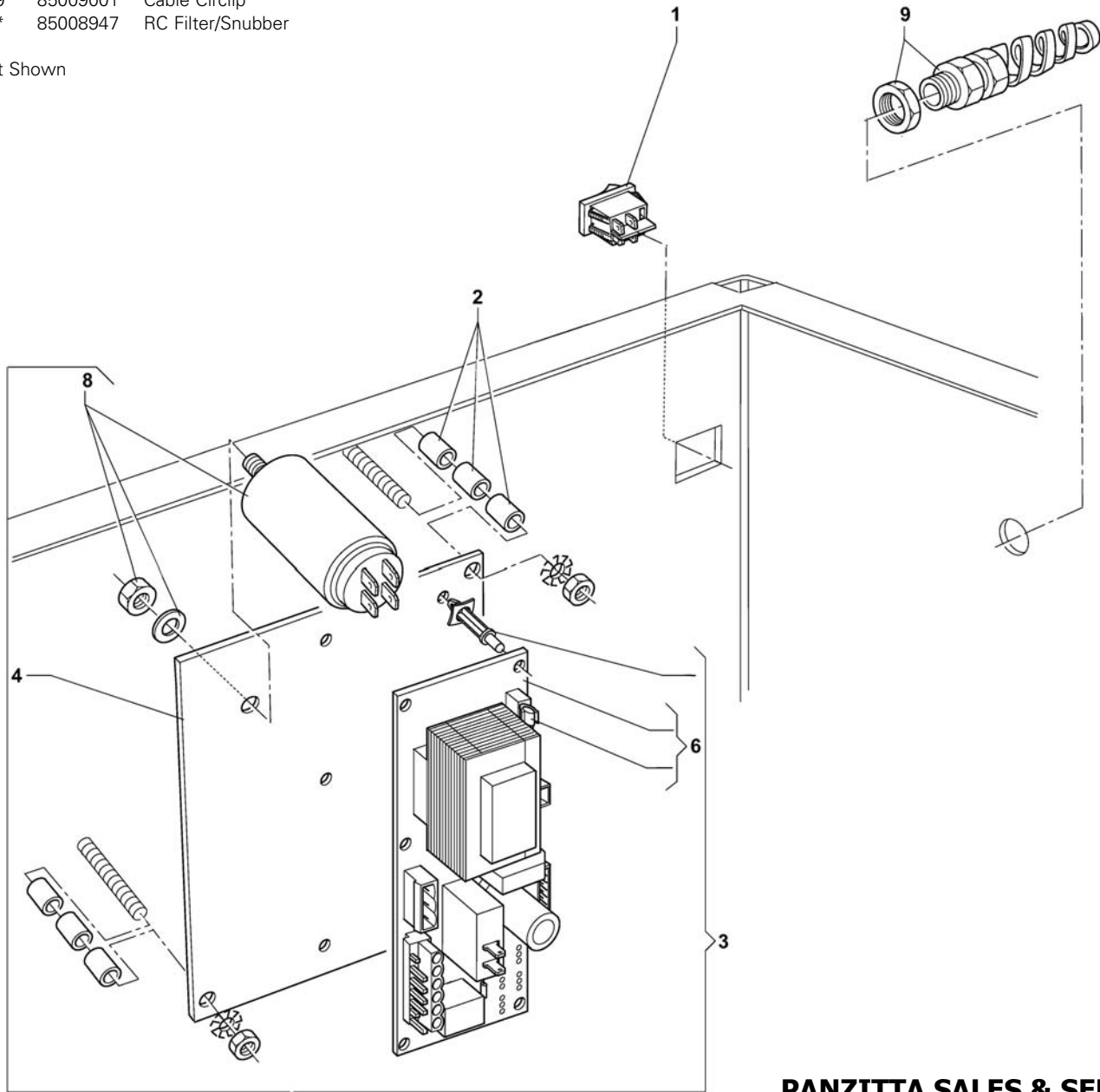

PANZITTA SALES & SERVICE
72 George Avenue
Wilkes-Barre, PA 18705
570-822-6720 800-822-6720
www.panzittasales.com

PANZITTA SALES & SERVICE
72 George Avenue
Wilkes-Barre, PA 18705
570-822-6720 800-822-6720
www.panzittasales.com

Power Panel (775)

ITEM	PART NO.	DESCRIPTION
1	85008907	Platform Switch
3	85008916	Power Plate Kit, 115V
6	85008917	Power Supply Board, 115V
7	85008918	Capacitor, 115V Assembly
11	85009001	Knurled Washer
*	85008947	RC Filter/Snubber

*Not Shown

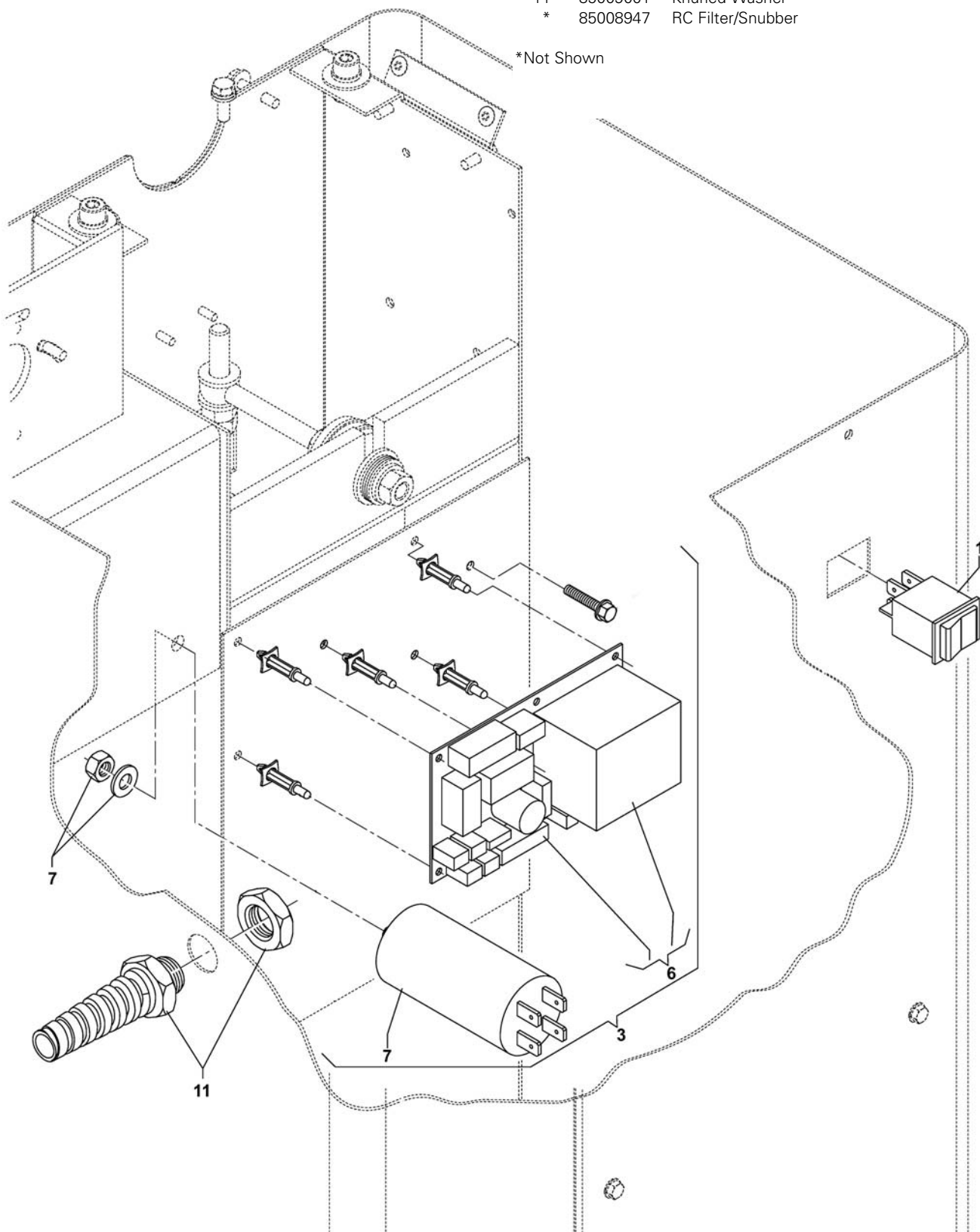

Wheel Guard

ITEM	DESCRIPTION
P/N 85008954	Wheel Guard
8	Wheel Guard
9	Self-threading Screw
11	Tube Chassis

ITEM	PART NO.	DESCRIPTION
1	85008968	Plug
3	85008967	Stop Ring
4	85009024	Bush
5	85008969	Support
10	85008971	Spring
16	85008911	Cable w/microswitch
17	85008972	Microswitch

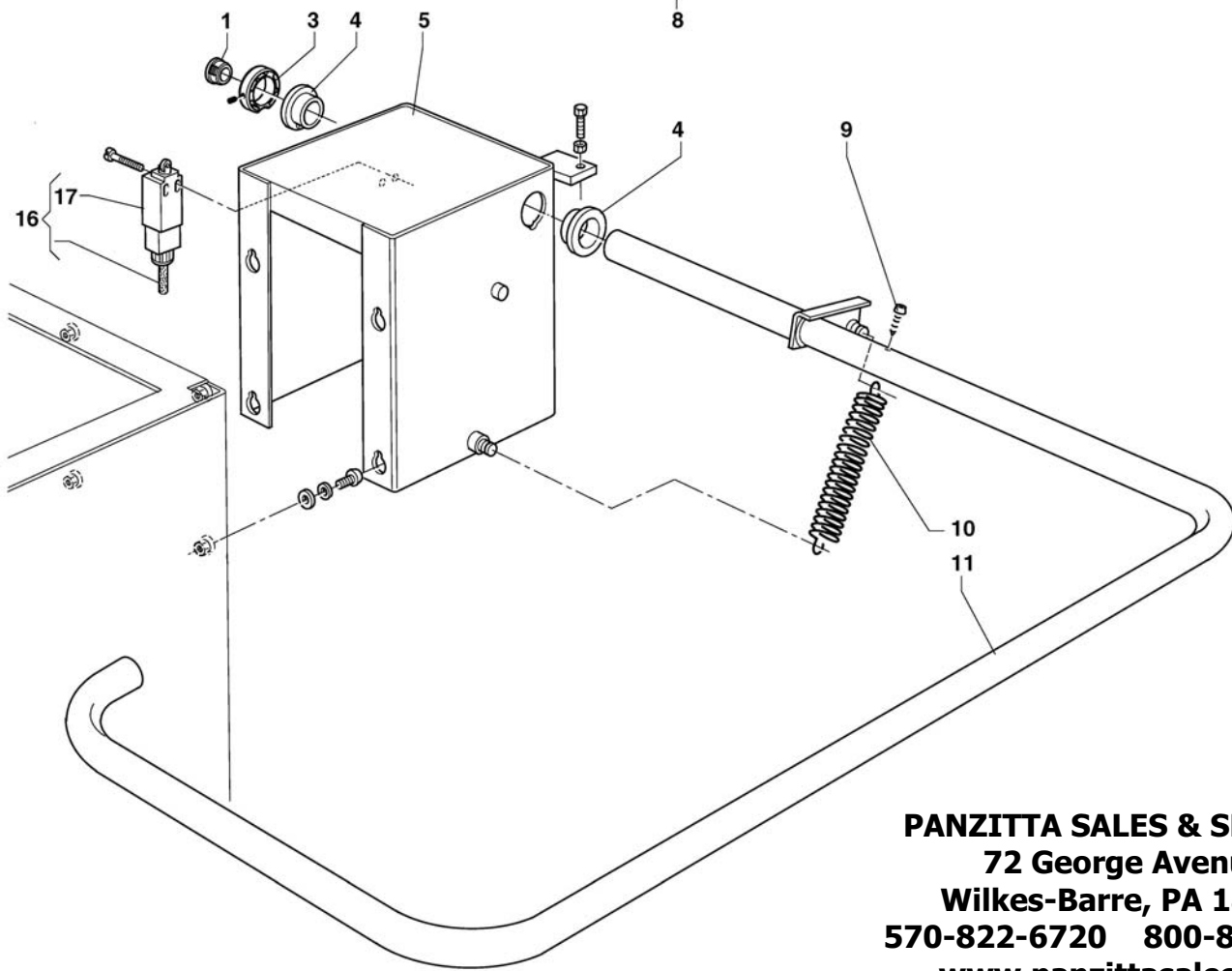
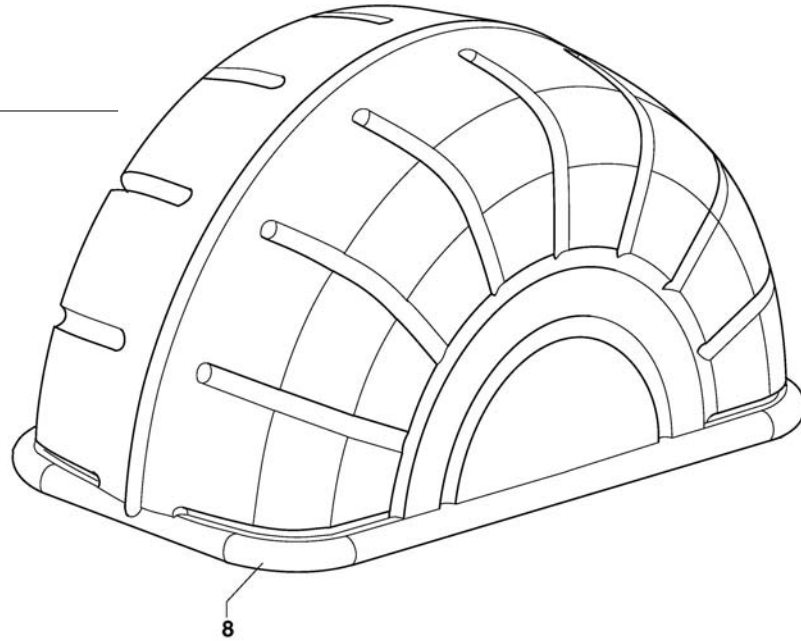

PANZITTA SALES & SERVICE
72 George Avenue
Wilkes-Barre, PA 18705
570-822-6720 800-822-6720
www.panzittasales.com

Harnesses

ITEM	PART NO.	DESCRIPTION
*	85008908	Hood Switch Harness
*	85008919	Encoder Cable
*	85008923	Display Power Ribbon
*	85008926	Ground Cable For Display
*	85009006	Power Cord from Wall, (775, 875)
*	85009008	Cord from Switch to MCB
*	85009025	Piezo/Display Cable

*Not Shown

PANZITTA SALES & SERVICE
72 George Avenue
Wilkes-Barre, PA 18705
570-822-6720 800-822-6720
www.panzittasales.com