

INSTALLATION AND OPERATION INSTRUCTIONS FOR MODELS NDL 5500 & NDL 7000 TWIN POST SURFACE MOUNTED ASYMMETRICAL LIFTS

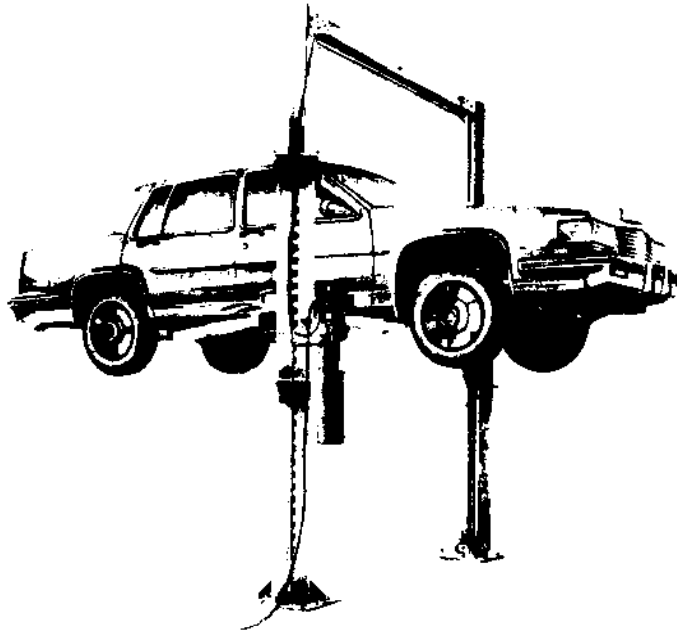

PANZITTA SALES & SERVICE
72 George Avenue
Wilkes-Barre, PA 18705
570-822-6720 800-822-6720
www.panzittasales.com

IMPORTANT: NOTE ANY DAMAGE OR SHORTAGE ON BILL OF LADING AND NOTIFY BEN PEARSON
TUBEMASTER CORP. SERVICE DEPARTMENT.

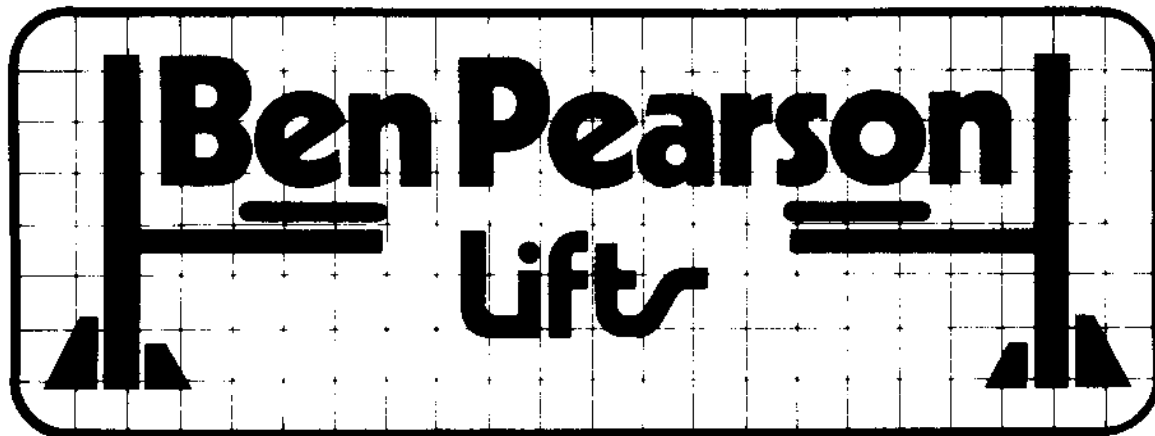

P.N. 83494
PRINTED IN USA

05/89

1-800-643-1346



INSTALLATION

LOCATION

1. Check height of building at lift site to determine if there is sufficient floor to ceiling height. (See Fig. 1). The absolute minimum is 147 3/8" to clear lift. Keep in mind pipes, duct work, overhead doors, etc. **NOTE:** Power unit can be mounted on the back side of either post.

2. **CAUTION! SPECIFICATIONS OF CONCRETE MUST BE ADHERED TO. FAILURE TO DO SO MAY RESULT IN LIFT AND/OR VEHICLE FALLING, ENDANGERING LIFE AND PROPERTY. DO NOT INSTALL LIFT TO AN ASPHALT OR SIMILAR SURFACE.**

3. Floors should be level and must be in good condition, steel reinforced 4" (inch) thick (3000 psi. min.). If concrete pads are used they must be a minimum of 1 foot thick. Connect these pads with a strip of steel reinforced concrete.

4. Lift must not be installed any closer than 1 (one) foot from existing exterior or interior walls, unless concrete is reinforced and a minimum of 8" (eight) inches deep.

INSTALLATION

5. Locate the centerline (A1-A2) of the intended area. (See Fig. 2). Locate the transverse centerline (C1-C2) through point "B".

6. Determine which side the power unit is to be located. Lay out width dimensions of lift. (See Fig.2). **NOTE:** Provide clearances for power unit. Post with power unit is the base post.

7. Locate the base post on the desired side to dimensions and plumb, add shims as required. **NOTE:** Do not shim more than 1/4" (inch) in any spot unless a longer anchor bolt is purchased. Using standard anchor bolts with greater than 1/4" (inch) of shims may cause the lift to fall

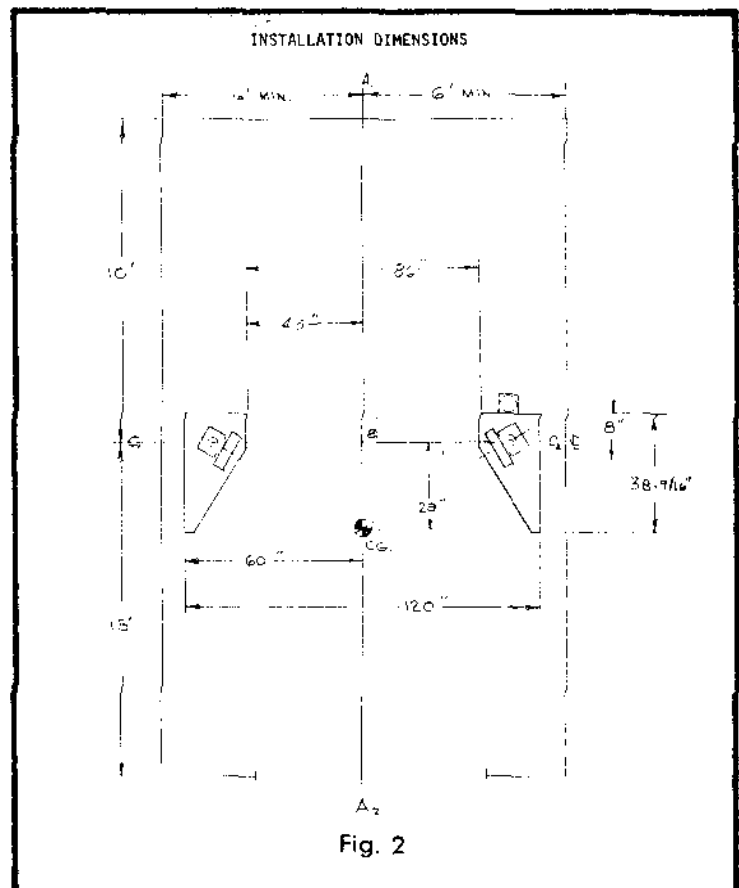
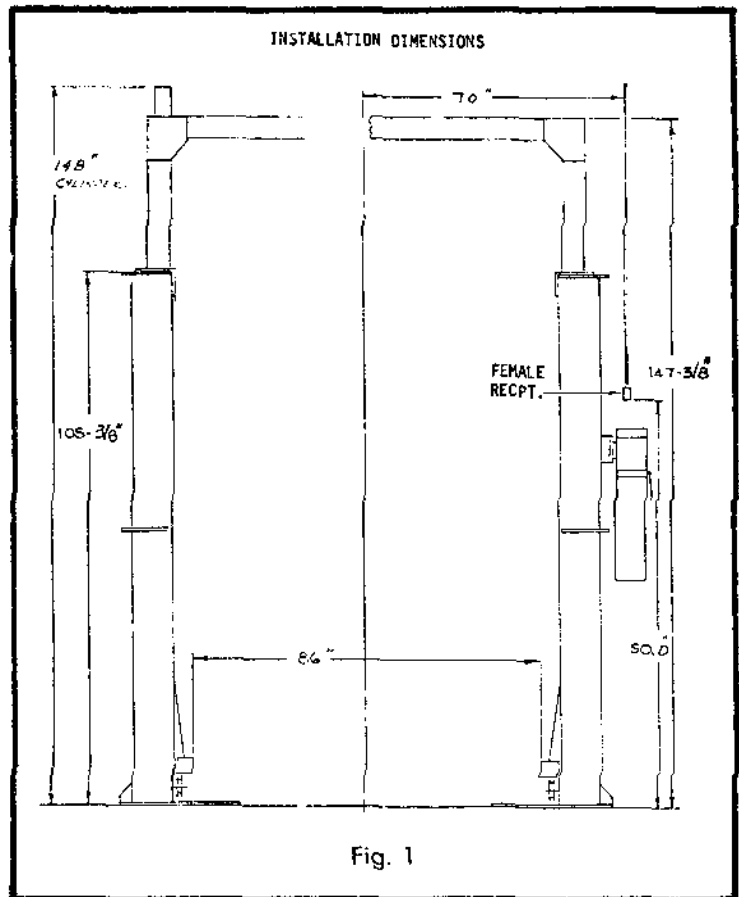

due to pull out from the concrete. **THE POST MUST BE PLUMB!**

8. Drill the anchor bolt holes using the post base as a template and centering the drill in the holes. Drill the holes 6" (inches) deep or through the concrete so they can be driven into the slab with a hammer and the holes patched if the lift is removed.

9. Clean dust from holes and install the anchor bolts into drilled holes. Torque nuts to 50-60 foot pounds. Check plumbness of the post. Adjust with shims if necessary.

10. Carefully measure distance to opposite (offside) post (See Fig. 2). Place post in position and adjust until 86" (inches) is measured inside post base plates. Measure diagonally to square lift.

11. Do not drill opposite (off-side) post holes at this time.

12. Assemble the two (2) overhead vertical post extensions to the horizontal cross over channel with (16) 3/8"-16NC x 1" long HFHSL screws and HFHSL nuts. **NOTE:** The cross over channel fits inside the post extensions. (See Fig. 3).

13. Install cable support to the two (2) top center holes in the cross over channel with flanges turned down. (See Fig. 3).

14. Install the equalizing cables over the sheaves at this time. (See Fig. 3). Square post extensions with cross over channel and tighten screws.

15. Install the switch bracket to the cross over channel with two (2) 5/16" x 3/4" long HFHSL screws and secure with HFHSL nuts. (See fig. 3). **NOTE:** On three phase power units the

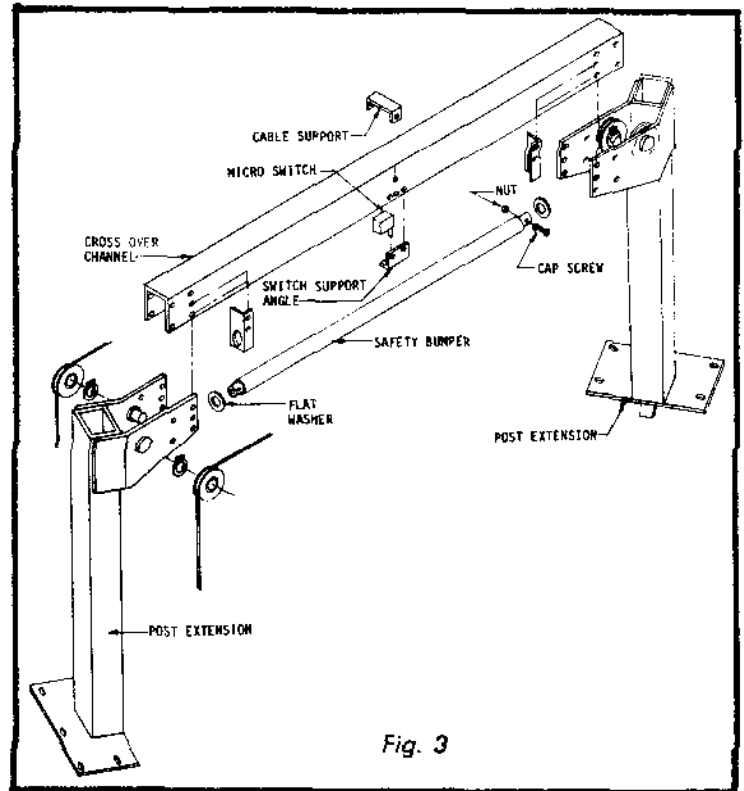

Fig. 3

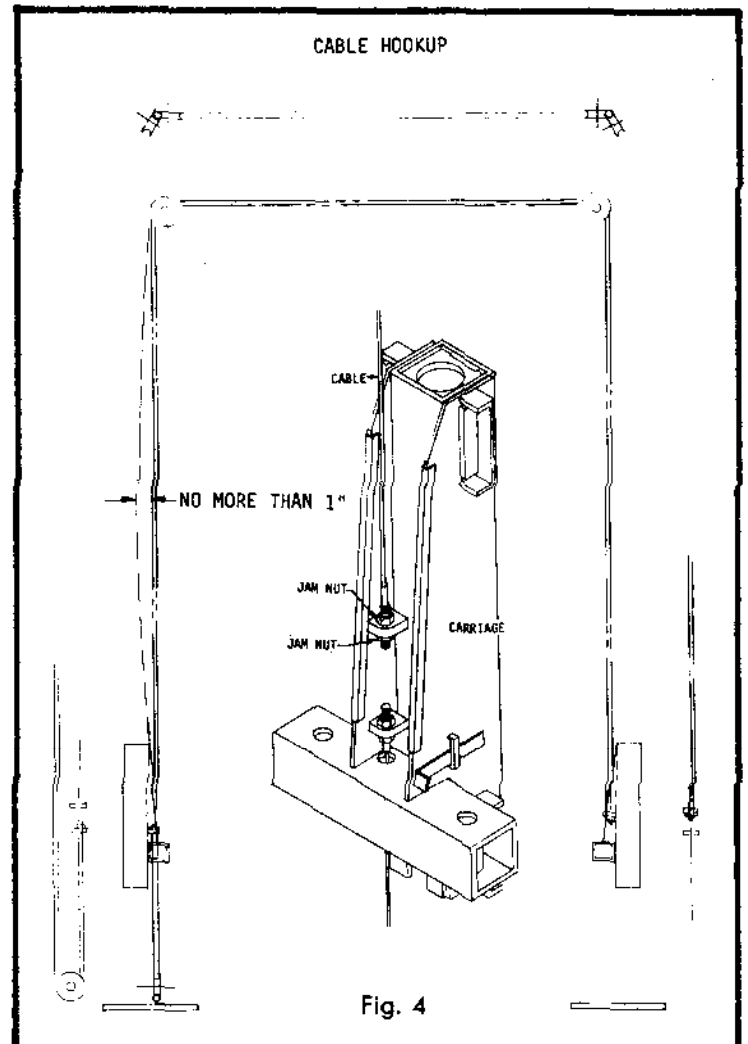

Fig. 4

screws will install directly into the tapped switch bracket.

16. Install the LH and RH support angles for the safety cut off to the cross over channel. (See fig. 3).

17. Install safety bumper (pipe with vinyl sleeve installed) through support angles. Install large washer over ends and secure with (2) two 5/16" x 1 1/2" long cap screws, lock washers and nuts. (See Fig. 3).

18. Lift assembled overhead structure to the top of both post and install with (8) eight 1/2" x 1 1/4" long HFHSL bolts and nuts. Use (4) 1/2 x 3/4" long HFHSL screws to install vertical legs to tapped pads on post.

19. Move offside post (only if necessary) until both upright vertical members of the overhead structure are vertical and tighten screws and nuts holding post to uprights.

20. Tighten all screws and plumb offside post. Using the holes in the post base as a template and centering the drill in the holes, drill holes in concrete as stated in paragraph (8).

21. Clean dust from holes and install anchor bolts. Torque nuts to 50-60 foot pounds. Recheck post for plumbness and add shims if necessary.

22. Manually raise each carriage to about 12" from the floor. Both must be latched in holes at the same distance from floor.

23. Run cable from point "A" (installed para. 14) through carriage around sheave "C" and install jam nuts on both sides of cable anchor at point "D" at front of carriage. Bring cable from sheave at point "B" and install jam nuts on both sides of cable anchor at point "E" on back side of carriage. (See Fig. 4).

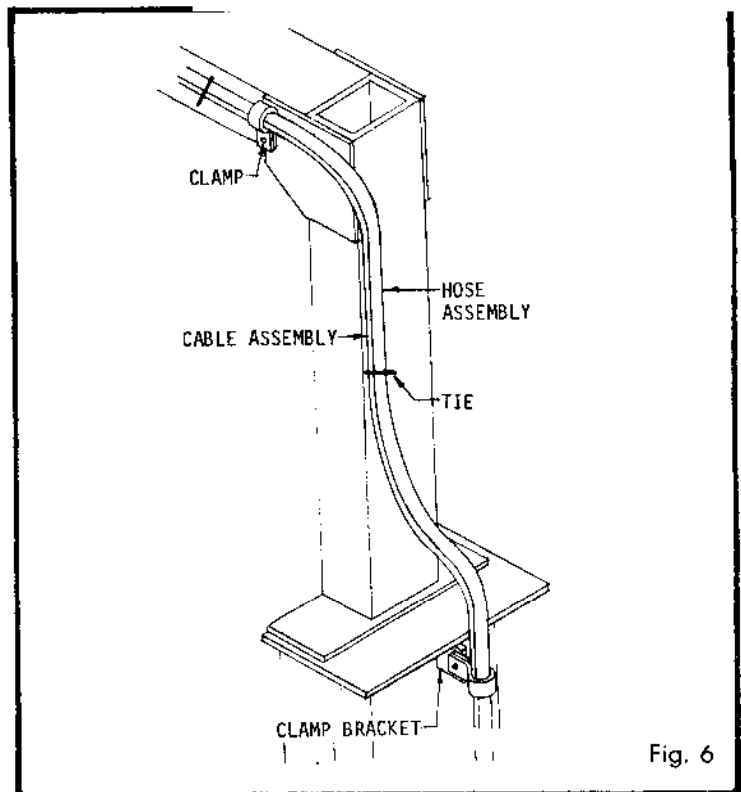
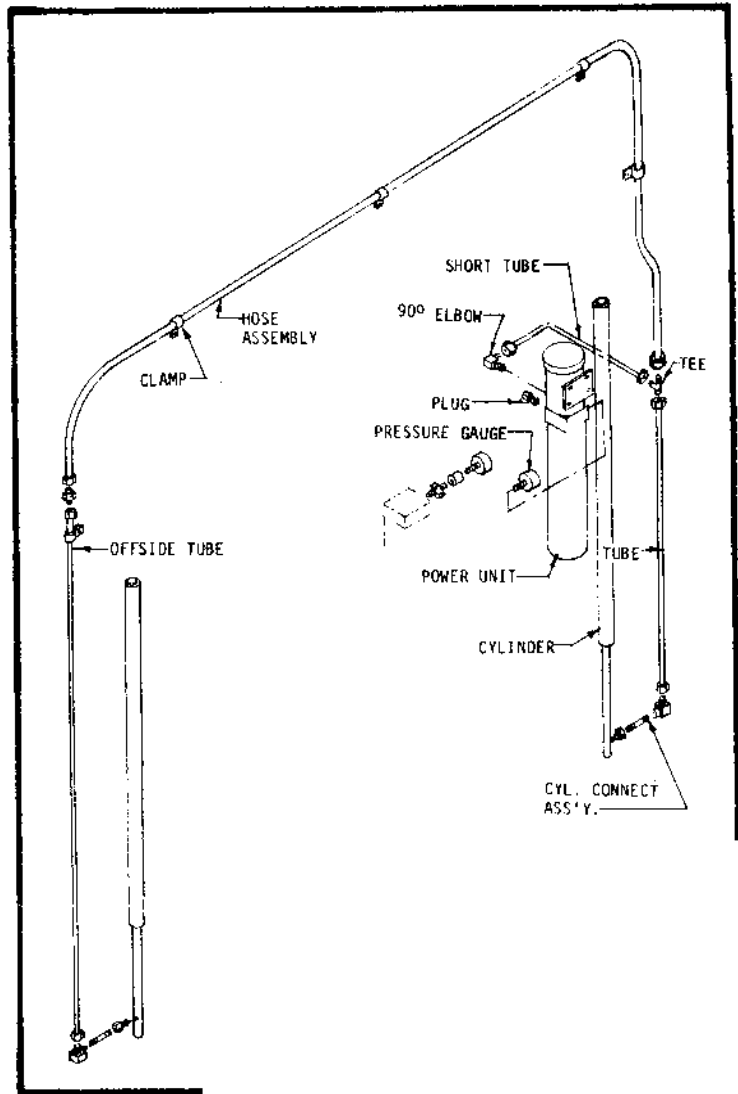

Fig. 6

24. Repeat step above for the other cable.

25. Tighten cables until both carriages are level and cables will not deflect more than 1" (inch) when pressure is applied by hand towards the back of the post. (See Fig. 4).

26. Remove the O'Ring plug (ORB) from the base cylinder's bottom port. Install cylinder connect assembly. (ORB adapter, 1/4 x 5 nipple, and 90 degree elbow) (Fig. 5).

27. Repeat step 25 for offside cylinder.

28. Install power unit with motor up and reservoir down to the base post with (4) 5/16" x 7/8" long cap screws, lock washers and nuts.

29. Remove shipping plugs from power unit ports. Install 90 degree elbow into port as shown in figure 5. Install O'Ring plug and pressure gauge as shown.

30. Install short tube assembly and complete piping as shown in figure 5 for both cylinders and over head.

31. Clamp hose and fittings as shown. Also clamp hose in center hole of cross over channel with 5/16 x 3/4" HFHSL screws and nuts. (See figs 5 & 6).

32. Install over travel cut off switch to angle bracket on bottom of cross over channel. (See Fig. 3). Position switch as near safety bumper as it can be positioned. Using plastic wire ties, clamp the electrical cable to the hose assembly previously installed. (See Fig. 6).

33. Fill power unit reservoir with 14 quarts of EXXON NUTO H46 or equal oil.

34. Plug power unit plug into 230 VAC single phase power source. **NOTE:** Female receptacle is furnished with the lift.

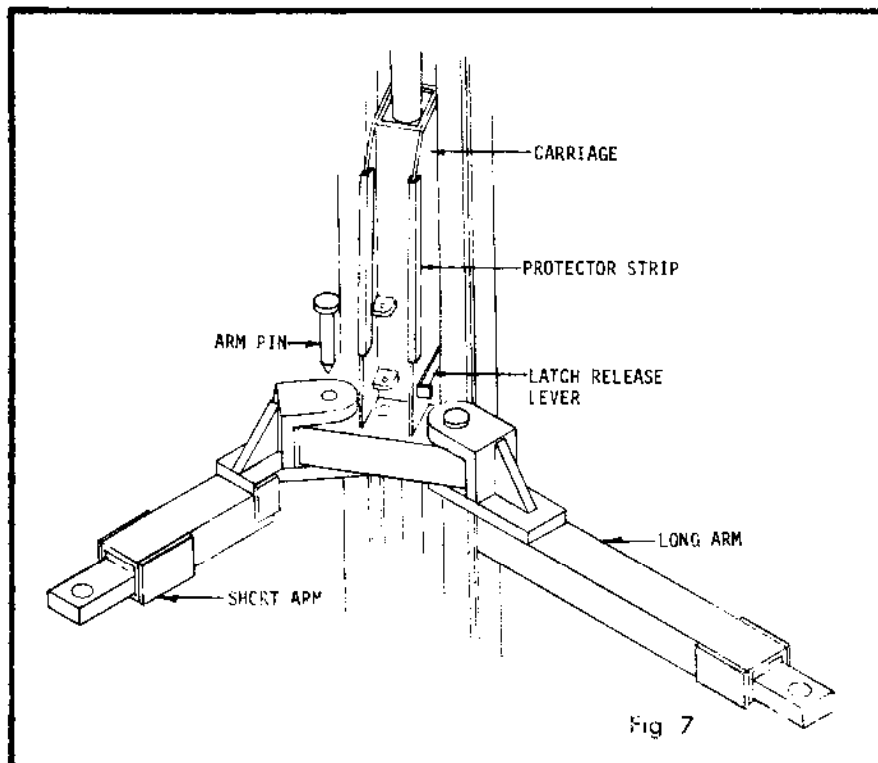

35. Operate the power unit and check height of carriages. Locking latches will click at the same time if carriages are level. Level if necessary by lowering carriages on locking latches. **NOTE:** Cables must be tight and have equal tension on each and be equal distance from post base plate.

36. Raise carriages to a comfortable working height and install all four lifting arms with extensions. (See Fig. 7). **NOTE:** Screw in bottom of lifting arm must be installed to prevent extension from sliding off end of arm. The short lifting arms will go to the front of lift and the long arms will go to the vehicles rear.

37. Raise lift to top of travel and pull latch release on each carriage to lower lift. (See Fig. 7).

38. Lower lift several feet and raise again. With lift raised and latches released, loosen pipe plugs in top of each cylinder approximately two turns and close when oil streams from vent.

39. Pull latches to lower lift. **NOTE:** If carriages are resting on safety latches, it will be necessary to slightly raise lift to be able to pull the latch release lever. (See Fig. 7).

AUTOMOBILE FRAME TYPE

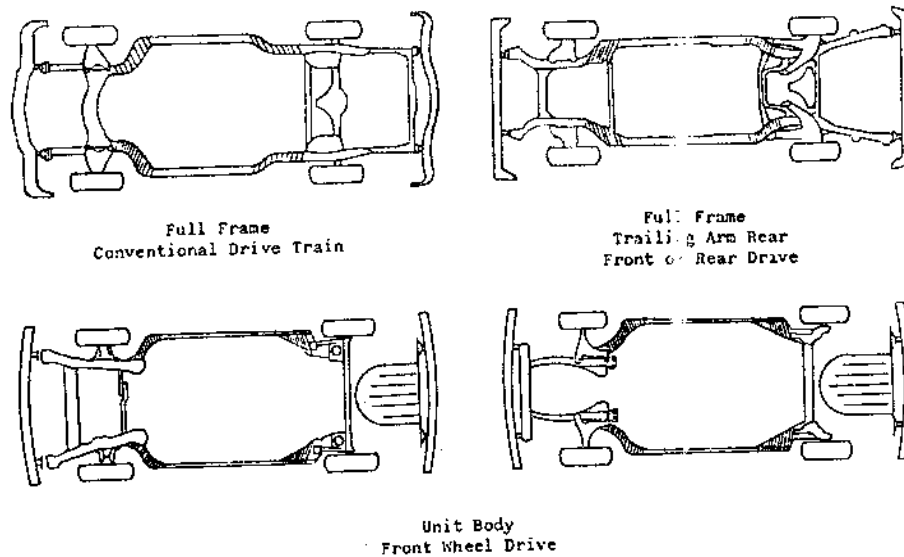

Unit Body with Front Stub Frame

Fig. 8

40. Check fittings for leaks and tighten if necessary.
41. Using a pole or long item, push up on over travel tube while raising the lift. Lift should stop immediately. **NOTE:** If this does not stop the lift, check the safety bumper to see if it moves freely. See if bumper contacts switch and if switch clicks when depressed.
42. If switch still does not stop the power unit, unplug power unit. Check wiring on switch. Switch should be wired to "C" (common) and "NC" normally closed. Correct if necessary.
43. If unit still does not perform, check power unit wiring by diagram in parts manual.
44. Install door protector strips to the two raw edges on each carriage. (See Fig. 7). Locate strips high enough so they do not interfere with latch release lever operation.
45. Grease all three sides of the two structural channels inside each post with a lithium based grease. This is a lubricant for the plastic pads on each carriage. Lubrication of these areas must be performed on a regular basis. We suggest monthly lubrication or any time that the carriage seems to drag or a noise is heard from the post. **NOTE:** Do not use oil on the plastic pads.

OPERATING INSTRUCTIONS

Shown on previous page are several automobile frame types with the preferred pick-up points marked. Unit body cars should generally be lifted near the rear torque arm mounts. A heavily braced area is usually located near the front fenderwell. Sometimes there is a stub frame on the front of the car. Never lift on strut rods or shock absorber mounts. Take care not to pinch or bend any brake lines.

The car should be pulled squarely into the bay and centered between the two posts as closely as possible. Positioning of the car long ways is especially important as the front of the car is usually heavier than the rear. This is true of front wheel drive cars, pickup trucks, and four wheel drive vehicles. Vans may be over balanced toward the front or rear. Check all vehicles for any loads or equipment that may cause unbalanced condition or may exceed the capacity of the lift. On heavy vehicles **DO NOT** extend the arms more than is necessary to reach a suitable pick up point.

TO RAISE VEHICLE

1. Position arms so that vehicle can be positioned between arms.
2. Position vehicle with front tire approximately 24 inches in front of post edge. Trucks and vans must be positioned further forward than with cars. Always determine the vehicles center of gravity.
3. Arms must be able to swing underneath vehicle for proper positioning.
4. Add pad extensions if necessary to make contact with frame at the proper lifting point on the vehicle.
5. Raise lift until pads make contact and recheck lifting points.
6. Lower lift and re-position if necessary.
7. Raise lift to desired height.

PANZITTA SALES & SERVICE
72 George Avenue
Wilkes-Barre, PA 18705
570-822-6720 800-822-6720
www.panzittasales.com

TO LOWER VEHICLE

8. Pull latch release (See Fig. 7) on each carriage toward the center of lift and lower lift. Safety latches will automatically reset if lift is raised.

9. If partially lowering lift to do additional work, latches must be manually reset to provide a safety stop for lift.

10. After lowering lift, remove arms from underneath vehicle before attempting to remove vehicle.

MAINTENANCE INSTRUCTIONS

1. Daily inspect equalizing cable for signs of wear and tightness. Replace or tighten.

2. Daily inspect for loose bolts and nuts. Tighten if necessary.

3. If hydraulic oil leak is spotted, immediately find cause and correct.

4. Check latch reset each time lift is lowered. Lift will make a clicking sound as unit is raised if working properly.

5. Check oil level, add oil if low.

6. Monthly lubricate channels where plastic slides run.

7. Keep area round lift clean and free of obstructions.

TROUBLE SHOOTING

PROBLEM

1. Motor does not run when button is pressed.

2. Motor runs but lift will not raise or raises partially.

3. Motor runs -- lift will not pick up heavy load. Inadequate pressure.

4. Oil blows out of breather cap.

5. No pressure or flow.

6. Jerky or non-uniform action of lift.

7. Foaming of oil.

8. Excess heating in system.

CAUSE

- A. Machine switch is not plugged in or main power switch is off.
 - B. Breaker is thrown or overload is tripped.
 - C. Thermal overload in motor may be tripped. Wait a few minutes and try again.
 - D. Check micro switch on power unit. Replace if faulty.
 - E. Check Wiring.
 - F. Replace motor.
-
- A. Trash under load holding check valve. Push handle down and then up.
 - B. Check oil level in reservoir. With lift down reservoir should be full.
-
- A. Relief valve setting too low. Raise lift until valve goes on relief; Check oil pressure and adjust to 2000 PSI.
 - B. Excessive oil leaking from front shaft seal of cylinder -- replace.
-
- A. Oil reservoir over filled. Remove oil until reservoir is full to vent screw when lift is fully lowered.
 - B. Breather cap not tight; Tighten.
-
- A. Check to see that motor is running, and in the right direction.
 - B. Reservoir is low of oil.
 - C. Key is sheared in pump.
-
- A. Air in system. Remove by removing vent screw and adding oil as unit is raised.
-
- A. Internal suction of air through pipe of line joints; Tighten.
 - B. At full stroke of cylinder, oil level may be insufficient; Add oil.
-
- A. Restricted orifice.
 - B. Relief Valve set too low.