

# CL Challenger Lifts



**Model#: CS1220**  
Heavy Duty Inground Lift  
12,000 lb. lifting capacity

## **Heavy-Duty Inground Lifts**

Challenger Lifts Heavy-Duty Inground Lifts are ideal for starting or expanding your commercial fleet service capabilities. Heavy-Duty Inground Lifts require less shop space than surface mounted lifts, maximizing the number of service bays.

The CS1220 is equipped with standard, medium and high extension stack adapters to accommodate a wide variety of Heavy-Duty vehicle pick up points. Challenger Heavy-Duty Inground Lifts are fully contained in a polymer housing to protect the environment.

Challenger is the exclusive manufacturer of the only 15,000 lb. capacity inground lift in the market. The CS1520 heavy-duty arms are engineered to lift heavier commercial vehicles.

## Features & Benefits:

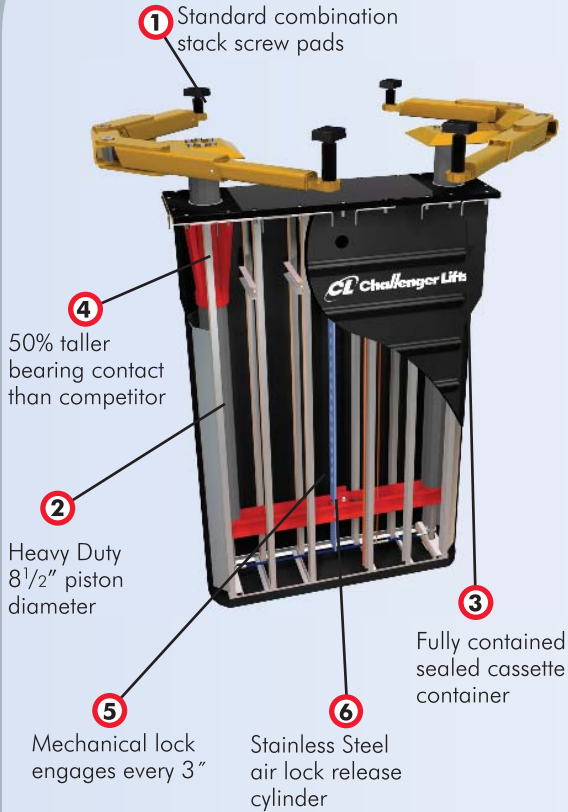

- 1 Accommodate a wide range of vehicle pick up points
- 2 Reduces wear while lifting heavy-duty vehicles
- 3 Specially engineered polymer minimizes risk of hydraulic fluid seeping into the ground as associated with low pressure inground lifts
- 4 Provides increased stability
- 5 Allows technician to work at their ergonomic working height to increase productivity and minimize fatigue
- 6 Prevents rust associated with condensation

For more information, contact your Authorized Challenger Lifts Distributor.

Model Number	CS1220	CS1520
Lifting Capacity	12,000 lb. (5442kg)	15,000 lb. (6806kg)
Rise Height*	81" (2057mm)	84 1/4" (2140mm)
Stroke	68" (1727mm)	
Width Overall	99" (2515mm)	71 1/2" (1816mm)
Drive-Thru Clearance	87" (2210mm)	NA
Reach (Arm Minimum)	32" (813mm)	26 1/4" (667mm)
Reach (Arm Maximum)	49 1/4" (1251mm)	43" (1092mm)
Adj. Adapter Height**	5 3/8"-7" (136.5-178mm)	6 1/2"-8 1/4" (165-210mm)
Adj. Adapter Height** (with Medium Extensions)	8 3/8"-10" (213-254mm)	10 1/2"-12 1/4" (267-311mm)
Adj. Adapter Height** (with High Extensions)	11 3/8"-13" (289-330mm)	14 1/2"-16 1/4" (368-413mm)
Capacity (per arm)	3,000 lb. (1361kg)	3,750 lb. (1701kg)
Motor	2HP	2HP
Voltage (1 Phase Std.)**	208v-230v	208v-230v
Speed of Rise	65 Sec.	80 Sec.
Air Required	75-125 psi	75-125 psi
Recommended Ceiling Height (plus height of tallest vehicle)	82"	85"

\* Rise height is measured with superstructure in highest position.

\*\* Medium and high auxiliary adapter extensions are standard.

\*\*\* Optional 3 phase electrical also available, please specify at time of order.

### Standard Stack Adapters:



**Model#: CS1520**

Heavy Duty Inground Lift  
15,000 lb. lifting capacity



**AAIA**  
Automotive Aftermarket  
Industry Association



**PANZITTA SALES & SERVICE**

72 George Avenue

Wilkes-Barre, PA 18705

570-822-6720 800-822-6720

www.panzittasales.com

GSA CONTRACT # GS-07F-8950D • CAGE CODE 0KD44

SIN#'s 253-23, 253-23A, 253-38 • DUNS# 79-435-3680

Challenger Lifts, Inc. reserves the right to make changes to specifications without notice and without making changes retroactive. Unloading, installation and oil not included.